

CERTIFICATE OF CONFORMITY



Equipment : UPS
Brand Name : 
Test Model No. : SRT3000RMXLI, SRT3000RMXLW-IEC, SRT2200RMXLI
Multiple Listing : SRT3000XLI, SRT3000XLW-IEC, SRT2200XLI
Applicant : American Power Conversion Holding Inc, Taiwan Branch
Test Report No. : CE150428D11



We, **Bureau Veritas Consumer Products Services (H.K.) Ltd., Taoyuan Branch**, declare that the equipment above has been tested in our facility and found compliance with the requirement limits of applicable standards, in accordance with the Directive 2004/108/EC. The test record, data evaluation and Equipment Under Test (EUT) configurations represented herein are true and accurate under the standards herein specified.

EN 62040-2:2006, Category C2

IEC 62040-2:2005, Category C2

EN 55022:2010 +AC:2011, Class A

IEC 61000-3-2:2014 ED.4.0, Class A

IEC 61000-3-3:2013 ED.3.0

IEC 61000-4-2:2008 ED.2.0

IEC 61000-4-3:2010 ED.3.2

IEC 61000-4-4:2012 ED.3.0

IEC 61000-4-5:2005 ED.2.0

IEC 61000-4-6:2013 ED.4.0

IEC 61000-4-8:2009 ED.2.0

IEC 61000-4-11:2004 ED. 2.0

IEC 61000-2-2:2002 ED.2.0

NOTE: The above IEC basic standards are applied with latest version if customer has no special requirement.

A handwritten signature in blue ink that reads 'Henry Lai'.

Henry Lai / Director

May 15, 2015



No. 47-2, 14th Ling, Chia Pau Vil., Lin Kou Dist., New Taipei City, Taiwan (R.O.C.)

Tel: 886-2-26052180 Fax: 886-2-26051924

<http://www.bureauveritas-adt.com> E-Mail: service.adt@tw.bureauveritas.com



CE EMC TEST REPORT

REPORT NO.: CE150428D11

TEST MODEL : SRT3000RMXLI, SRT3000RMXLW-IEC, SRT2200RMXLI

SERIES MODEL: SRT3000XLI, SRT3000XLW-IEC, SRT2200XLI

RECEIVED: Apr. 28, 2015

TESTED: Apr. 30 ~ May 13, 2015

ISSUED: May 15, 2015

APPLICANT: American Power Conversion Holding Inc, Taiwan Branch

ADDRESS: 3F, No. 205, Sec. 3, Beishin Rd., Shindian City, Taipei,
Taiwan 231, R.O.C.

ISSUED BY: Bureau Veritas Consumer Products Services (H.K.) Ltd.,
Taoyuan Branch

LAB LOCATION: No. 47-2, 14th Ling, Chia Pau Vil., Lin Kou Dist., New
Taipei City, Taiwan (R.O.C.)

This report should not be used by the client to claim product certification, approval, or endorsement by TAF or any government agencies.



This report is for your exclusive use. Any copying or replication of this report to or for any other person or entity, or use of our name or trademark, is permitted only with our prior written permission. This report sets forth our findings solely with respect to the test samples identified herein. The results set forth in this report are not indicative or representative of the quality or characteristics of the lot from which a test sample was taken or any similar or identical product unless specifically and expressly noted. Our report includes all of the tests requested by you and the results thereof based upon the information that you provided to us. You have 60 days from date of issuance of this report to notify us of any material error or omission caused by our negligence, provided, however, that such notice shall be in writing and shall specifically address the issue you wish to raise. A failure to raise such issue within the prescribed time shall constitute your unqualified acceptance of the completeness of this report, the tests conducted and the correctness of the report contents. Unless specific mention, the uncertainty of measurement has been explicitly taken into account to declare the compliance or non-compliance to the specification



Table of Contents

RELEASE CONTROL RECORD.....	5
1 CERTIFICATION.....	6
2 SUMMARY OF TEST RESULTS.....	7
2.1 MEASUREMENT UNCERTAINTY	9
3 GENERAL INFORMATION	10
3.1 GENERAL DESCRIPTION OF EUT.....	10
3.2 DESCRIPTION OF TEST MODES.....	11
3.3 GENERAL DESCRIPTION OF APPLIED STANDARDS	12
3.4 DESCRIPTION OF SUPPORT UNITS.....	13
4 EMISSION TEST.....	17
4.1 CONDUCTED EMISSION MEASUREMENT	17
4.1.1 LIMITS OF CONDUCTED EMISSION MEASUREMENT.....	17
4.1.2 TEST INSTRUMENTS	18
4.1.3 TEST PROCEDURE	19
4.1.4 DEVIATION FROM TEST STANDARD	19
4.1.5 TEST SETUP	19
4.1.6 EUT OPERATING CONDITIONS.....	20
4.1.7 TEST RESULTS (1)	21
4.1.8 TEST RESULTS (2)	23
4.1.9 TEST RESULTS (3)	25
4.1.10 TEST RESULTS (4)	27
4.1.11 TEST RESULTS (5)	29
4.1.12 TEST RESULTS (6)	31
4.1.13 TEST RESULTS (7)	33
4.1.14 TEST RESULTS (8)	35
4.1.15 TEST RESULTS (9)	37
4.2 CONDUCTED EMISSION MEASUREMENT AT TELECOMMUNICATION PORTS.....	39
4.2.1 LIMIT OF CONDUCTED COMMON MODE DISTURBANCE AT TELECOMMUNICATION PORTS	39
4.2.2 TEST INSTRUMENTS	40
4.2.3 TEST PROCEDURE	41
4.2.4 DEVIATION FROM TEST STANDARD	42
4.2.5 TEST SETUP	43
4.2.6 EUT OPERATING CONDITIONS.....	45
4.2.7 TEST RESULTS (1)	46
4.2.8 TEST RESULTS (2)	48
4.2.9 TEST RESULTS (3)	50
4.3 RADIATED EMISSION MEASUREMENT	52
4.3.1 LIMITS OF RADIATED EMISSION MEASUREMENT.....	52
4.3.2 TEST INSTRUMENTS	52
4.3.3 TEST PROCEDURE	53
4.3.4 DEVIATION FROM TEST STANDARD	53



A D T

4.3.5	TEST SETUP	54
4.3.6	EUT OPERATING CONDITIONS.....	54
4.3.7	TEST RESULTS (1)	55
4.3.8	TEST RESULTS (2)	57
4.3.9	TEST RESULTS (3)	59
4.3.10	TEST RESULTS (4)	61
4.3.11	TEST RESULTS (5)	63
4.3.12	TEST RESULTS (6)	65
4.3.13	TEST RESULTS (7)	67
4.3.14	TEST RESULTS (8)	69
4.3.15	TEST RESULTS (9)	71
4.4	HARMONICS CURRENT MEASUREMENT	73
4.4.1	LIMITS OF HARMONICS CURRENT MEASUREMENT.....	73
4.4.2	TEST INSTRUMENTS	73
4.4.3	TEST PROCEDURE	74
4.4.4	DEVIATION FROM TEST STANDARD	74
4.4.5	TEST SETUP	74
4.4.6	EUT OPERATING CONDITIONS.....	75
4.4.7	TEST RESULTS (1)	76
4.4.8	TEST RESULTS (2)	77
4.5	LIMITS OF VOLTAGE FLUCTUATION AND FLICKS MEASUREMENT	78
4.5.1	TEST INSTRUMENTS	78
4.5.2	TEST PROCEDURE	78
4.5.3	DEVIATION FROM TEST STANDARD	79
4.5.4	TEST SETUP	79
4.5.5	EUT OPERATING CONDITIONS.....	79
4.5.6	TEST RESULTS (1)	80
4.5.7	TEST RESULTS (2)	81
5	IMMUNITY TEST	82
5.1	GENERAL DESCRIPTION OF EN 62040-2.....	82
5.2	SPECIFIC IMMUNITY REQUIREMENTS BY MANUFACTURER.....	83
5.3	GENERAL PERFORMANCE CRITERIA DESCRIPTION	83
5.4	EUT OPERATING CONDITION	83
5.5	ELECTROSTATIC DISCHARGE IMMUNITY TEST (ESD).....	84
5.5.1	TEST SPECIFICATION	84
5.5.2	TEST INSTRUMENTS	84
5.5.3	TEST PROCEDURE	85
5.5.4	DEVIATION FROM TEST STANDARD	85
5.5.5	TEST SETUP	86
5.5.6	TEST RESULTS (1)	87
5.5.7	TEST RESULTS (2)	88
5.6	RADIATED, RADIO-FREQUENCY, ELECTROMAGNETIC FIELD IMMUNITY TEST (RS).....	89
5.6.1	TEST SPECIFICATION	89
5.6.2	TEST INSTRUMENTS	89
5.6.3	TEST PROCEDURE	90
5.6.4	DEVIATION FROM TEST STANDARD	90
5.6.5	TEST SETUP	90



A D T

5.6.6	TEST RESULTS.....	91
5.7	ELECTRICAL FAST TRANSIENT/BURST IMMUNITY TEST (EFT)	92
5.7.1	TEST SPECIFICATION	92
5.7.2	TEST INSTRUMENTS	92
5.7.3	TEST PROCEDURE	92
5.7.4	DEVIATION FROM TEST STANDARD	92
5.7.5	TEST SETUP	93
5.7.6	TEST RESULTS.....	94
5.8	SURGE IMMUNITY TEST	95
5.8.1	TEST SPECIFICATION	95
5.8.2	TEST INSTRUMENTS	95
5.8.3	TEST PROCEDURE	96
5.8.4	DEVIATION FROM TEST STANDARD	96
5.8.5	TEST SETUP	96
5.8.6	TEST RESULTS.....	97
5.9	IMMUNITY TO CONDUCTED DISTURBANCES INDUCED BY RF FIELDS (CS).....	98
5.9.1	TEST SPECIFICATION	98
5.9.2	TEST INSTRUMENTS	98
5.9.3	TEST PROCEDURE	99
5.9.4	DEVIATION FROM TEST STANDARD	99
5.9.5	TEST SETUP	100
5.9.6	TEST RESULTS.....	101
5.10	POWER FREQUENCY MAGNETIC FIELD IMMUNITY TEST.....	102
5.10.1	TEST SPECIFICATION	102
5.10.2	TEST INSTRUMENTS	102
5.10.3	TEST PROCEDURE	102
5.10.4	DEVIATION FROM TEST STANDARD	102
5.10.5	TEST SETUP	103
5.10.6	TEST RESULTS.....	104
5.11	VOLTAGE DIPS AND INTERRUPTIONS.....	105
5.11.1	TEST SPECIFICATION	105
5.11.2	TEST INSTRUMENTS	105
5.11.3	TEST ARRANGEMENT	105
5.11.4	SUPPLEMENTARY INFORMATION	105
5.11.5	TEST SETUP	106
5.11.6	TEST RESULTS.....	107
5.12	IMMUNITY TO LOW-FREQUENCY SIGNALS.....	108
5.12.1	TEST SPECIFICATION	108
5.12.2	TEST INSTRUMENTS	108
5.12.3	TEST PROCEDURE	108
5.12.4	DEVIATION FROM TEST STANDARD	108
5.12.5	TEST SETUP	108
5.12.6	TEST RESULTS.....	109
6	PHOTOGRAPHS OF THE TEST CONFIGURATION.....	110
7	APPENDIX - INFORMATION ON THE TESTING LABORATORIES.....	135
8	APPENDIX A - ADD RS TEST	136



A D T

RELEASE CONTROL RECORD

ISSUE NO.	REASON FOR CHANGE	DATE ISSUED
CE150428D11	Original release	May 15, 2015



1 CERTIFICATION

PRODUCT: UPS

BRAND: 
by Schneider Electric

TEST MODEL : SRT3000RMXLI, SRT3000RMXLW-IEC, SRT2200RMXLI
SERIES MODEL: SRT3000XLI, SRT3000XLW-IEC, SRT2200XLI

APPLICANT: American Power Conversion Holding Inc, Taiwan Branch

TEST SAMPLE: ENGINEERING SAMPLE

TESTED: Apr. 30 ~ May 13, 2015

STANDARDS: **EN 62040-2:2006, Category C2**
IEC 62040-2:2005, Category C2
EN 55022:2010 +AC:2011, Class A
IEC 61000-3-2:2014 ED.4.0, Class A
IEC 61000-3-3:2013 ED.3.0
IEC 61000-4-2:2008 ED.2.0
IEC 61000-4-3:2010 ED.3.2
IEC 61000-4-4:2012 ED.3.0
IEC 61000-4-5:2005 ED.2.0
IEC 61000-4-6:2013 ED.4.0
IEC 61000-4-8:2009 ED.2.0
IEC 61000-4-11:2004 ED. 2.0
IEC 61000-2-2:2002 ED.2.0

The above equipment has been tested by **Bureau Veritas Consumer Products Services (H.K.) Ltd., Taoyuan Branch**, and found compliance with the requirement of the above standards. The test record, data evaluation & Equipment Under Test (EUT) configurations represented herein are true and accurate accounts of the measurements of the sample's EMC characteristics under the conditions specified in this report.

Prepared by :  , **Date:** May 15, 2015
Sandra Lin / Specialist

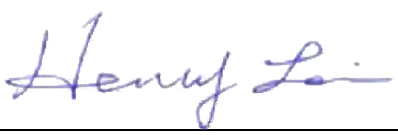
Approved by :  , **Date:** May 15, 2015
Henry Lai / Director

2 SUMMARY OF TEST RESULTS

The EUT has been tested according to the following specifications:

Standard	Test Type	Result	Remarks
EN 62040-2:2006, Category C2	Conducted Test	PASS	Meets Category C2 Limit Minimum passing margin is –6.21 dB at 13.71094 MHz
IEC 62040-2:2005, Category C2	Radiated Test	PASS	Meets Category C2 Limit Minimum passing margin is –4.09 dB at 36.39 MHz
EN 55022:2010 +AC:2011, Class A <Additional Test>	Conducted Test (telecom port)	PASS	Meets Class A Limit Minimum passing margin is –5.71 dB at 13.86192 MHz
IEC 61000-3-2:2014 ED.4.0	Harmonic current emissions	PASS	Meets Class A Limit
IEC 61000-3-3:2013 ED.3.0 <Additional Test>	Voltage fluctuations & flicker	PASS	Meets the requirements.
IEC 61000-4-2:2008 ED.2.0	Electrostatic discharge immunity test	PASS	Meets the requirements of Performance Criterion B
IEC 61000-4-3:2010 ED.3.2	Radiated, radio-frequency, electromagnetic field immunity test	PASS	Meets the requirements of Performance Criterion A
IEC 61000-4-4:2012 ED.3.0	Electrical fast transient / burst immunity test.	PASS	Meets the requirements of Performance Criterion B
IEC 61000-4-5:2005 ED.2.0	Surge immunity test	PASS	Meets the requirements of Performance Criterion B
IEC 61000-4-6:2013 ED.4.0	Immunity to conducted disturbances, induced by radio-frequency fields	PASS	Meets the requirements of Performance Criterion A
IEC 61000-4-8:2009 ED.2.0	Power frequency magnetic field immunity test.	PASS	Meets the requirements of Performance Criterion A



A D T

Standard	Test Type	Result	Remarks
IEC 61000-4-11:2004 ED. 2.0 <Additional Test>	Voltage dips and interruptions	PASS	Voltage Dips: >95% reduction – 0.5 period, Performance Criterion B >95% reduction – 1 period, Performance Criterion B 30% reduction – 25 periods, Performance Criterion B Voltage Interruptions: >95% reduction – 250 periods, Performance Criterion B
IEC 61000-2-2:2002 ED.2.0	Immunity to low-frequency signals	PASS	Meets the requirements of Performance Criterion A

2.1 MEASUREMENT UNCERTAINTY

Where relevant, the following measurement uncertainty levels have been estimated for tests performed on the EUT as specified in CISPR 16-4-2:

The listed uncertainties are the worst case uncertainty for the entire range of measurement. Please note that the uncertainty values are provided for informational purposes only and are not used in determining the PASS/FAIL results.

MEASUREMENT	EXPENDED UNCERTAINTY (K=2) (±)
Conducted emissions	3.43 dB
Conducted emissions at telecom port	3.62 dB
Radiated emissions	4.26 dB

3 GENERAL INFORMATION

3.1 GENERAL DESCRIPTION OF EUT

PRODUCT	UPS
TEST MODEL	SRT3000RMXLI, SRT3000RMXLW-IEC, SRT2200RMXLI
SERIES MODEL	SRT3000XLI, SRT3000XLW-IEC, SRT2200XLI
POWER SUPPLY	Switching Rating: Refer to note below Power Cord: Non-shielded AC 3-pin (2.0m)
Operating Software	UPS k04.4
Operating Hardware	HW02b_2015_MAR25
DATA CABLE SUPPLIED	Non-Shielded RS-232 cable (5.0m) Shielded USB cable (2.0m) Shielded USB cable (5.0m)

NOTE:

1. The EUT is an Uninterruptible Power Systems, which has several models with difference, as follows:

Model No.	AC I/P	AC O/P
SRT3000RMXLI	220/230/240V, 16A, 50/60Hz	2700W
SRT3000XLI		
SRT3000RMXLW-IEC	208/220/230/240V, 16A, 50/60Hz	2700W
SRT3000XLW-IEC		
SRT2200RMXLI	220/230/240V, 13A, 50/60Hz	1800W
SRT2200XLI		

During the test, the Model No.: **SRT3000RMXLI, SRT3000RMXLW-IEC, SRT2200RMXLI** were selected as the representative one for the test and therefore only its test data were recorded in this report.

2. The EUT consumes power from a battery pack, which has several models could be chosen, as the following:

Brand	Model	Specification
	SRT72BP	APC Smart-UPS SRT 72V 2200VA LV/HV Battery pack
	SRT72RMBP	
	SRT96BP	APC Smart-UPS SRT 96V 3000VA LV/HV Battery pack
	SRT96RMBP	

3. For more detailed features description, please refer to Manufacturer's specifications.

3.2 DESCRIPTION OF TEST MODES

Test modes are presented in the report as below.

Test Item	Test Mode	Model No.	Test Condition	Input Power	
Conducted emission test	Mode 1	A	Online mode	230V/ 50Hz	
		B	Green mode		
		C	Battery mode		
	Mode 2	A	SRT3000RMXLW-IEC	Online mode	208V/ 50Hz
		B		Green mode	
		C		Battery mode	
	Mode 3	A	SRT2200RMXLI	Online mode	230V/ 50Hz
		B		Green mode	
		C		Battery mode	
Conducted emissions at telecom port	Mode 1	SRT3000RMXLI	LAN (10/ 100Mbps)	230V/ 50Hz	
	Mode 2	SRT3000RMXLW-IEC	LAN (10/ 100Mbps)	208V/ 50Hz	
	Mode 3	SRT2200RMXLI	LAN (10/ 100Mbps)	230V/ 50Hz	

The idle mode of conducted emission test at telecom port was pre-tested based on the worst case of link mode. Due to emissions of idle mode being very low compared to link mode, only the link mode data were presented in the test report.

Radiated emission test	Mode 1	A	SRT3000RMXLI	Online mode	230V/ 50Hz
		B		Green mode	
		C		Battery mode	
	Mode 2	A	SRT3000RMXLW-IEC	Online mode	208V/ 50Hz
		B		Green mode	
		C		Battery mode	
	Mode 3	A	SRT2200RMXLI	Online mode	230V/ 50Hz
		B		Green mode	
		C		Battery mode	
Harmonics, Flicker, Immunity tests	Mode 2	A	SRT3000RMXLW-IEC	Online mode	230V/ 50Hz
	Mode 3	A	SRT2200RMXLI	Online mode	230V/ 50Hz

3.3 GENERAL DESCRIPTION OF APPLIED STANDARDS

The EUT is an UPS, according to the specifications of the manufacturers, it must comply with the requirements of the following standards:

EN 62040-2:2006, Category C2

IEC 62040-2:2005, Category C2

EN 55022:2010 +AC:2011, Class A

IEC 61000-3-2:2014 ED.4.0, Class A

IEC 61000-3-3:2013 ED.3.0

IEC 61000-4-2:2008 ED.2.0

IEC 61000-4-3:2010 ED.3.2

IEC 61000-4-4:2012 ED.3.0

IEC 61000-4-5:2005 ED.2.0

IEC 61000-4-6:2013 ED.4.0

IEC 61000-4-8:2009 ED.2.0

IEC 61000-4-11:2004 ED. 2.0

IEC 61000-2-2:2002 ED.2.0

Notes: The above IEC basic standards are applied with latest version if customer has no special requirement.



3.4 DESCRIPTION OF SUPPORT UNITS

The EUT has been tested as an independent unit together with other necessary accessories or support units. The following support units or accessories were used to form a representative test configuration during the tests.

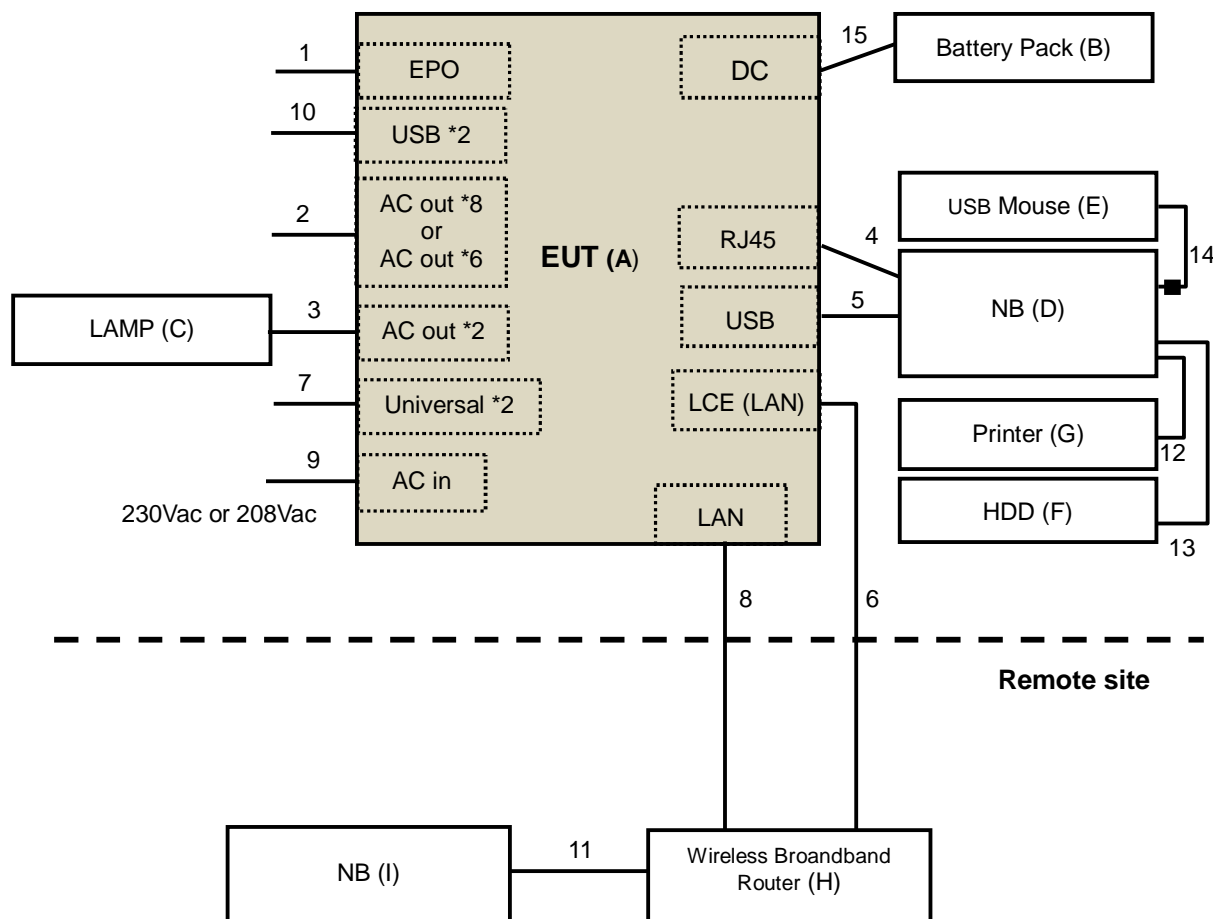
Emission tests (Harmonics & Flicker excluded):





ID	Product	Brand	Model No.	Serial No.	FCC ID	Remarks
A.	EUT		SRT3000RMXLI	QS1430242269	N/A	Supplied by client
			SRT3000RMXLW-IEC	QS1430242314		
			SRT2200RMXLI	QS1430242228		
B.	Battery Pack <only for Mode 3>		SRT72RMBP	5A1430T02020	N/A	Supplied by client
	Battery Pack <only for Mode 1 & 2>		SRT96RMBP	5A1430T02143	N/A	Supplied by client
C.	LAMP	N/A	N/A	N/A	N/A	Supplied by client
D.	NB	DELL	PP18L	N/A	FCC DoC Approved	Supplied by client
E.	USB Mouse	Microsoft	1113	9170515896637	FCC DoC Approved	Provided by Lab
F.	USB 3.0 Hard Disk	WD	WDBACY5000ABL -PESN	WX11E91ED733	FCC DoC Approved	Provided by Lab
G.	PRINTER	LEXMARK	Z33	03331652570	FCC DoC Approved	Provided by Lab
H.	Wireless Broadband Router	BUFFALO	WHR-G300N-AP	74059085108007	FDI-09101528-0	Provided by Lab
I.	NB	DELL	PP18L	N/A	FCC DoC Approved	Supplied by client

Note:

1. All power cords of the above support units are non-shielded (1.8m).
2. Items H-I acted as communication partners to transfer data.



No.	Cable	Qty.	Length (m)	Shielded (Yes/ No)	Cores (Number)	Remark
1.	EPO cable	1	5.0	N	0	Supplied by client
2.	AC power cable <only for Mode 1 & 3>	8	1.8	N	0	Provided by Lab
	AC power cable <only for Mode 2>	6	1.8	N	0	Provided by Lab
3.	AC power cable	2	2.2	N	0	Provided by Lab
4.	RJ45 to RS232 cable	1	5.0	N	0	Supplied by client
5.	USB cable	1	5.0	Y	0	Supplied by client
6.	LCE (LAN) cable	1	10	N	0	Supplied by client
7.	Universal I/O cable	2	5.0	N	0	Supplied by client
8.	LAN cable	1	10	N	0	Provided by Lab
9.	AC Power cord	1	2.0	N	0	Supplied by client
10.	USB cable	2	1.8	Y	0	Provided by Lab
11.	LAN cable	1	1.5	N	0	Provided by Lab
12.	USB cable	1	2.0	Y	0	Provided by Lab
13.	USB cable	1	1.8	Y	0	Provided by Lab
14.	USB cable	1	1.8	Y	1	Provided by Lab
15.	DC cable	1	1.8	N	0	Provided by Lab

Note: The core(s) is(are) originally attached to the cable(s).

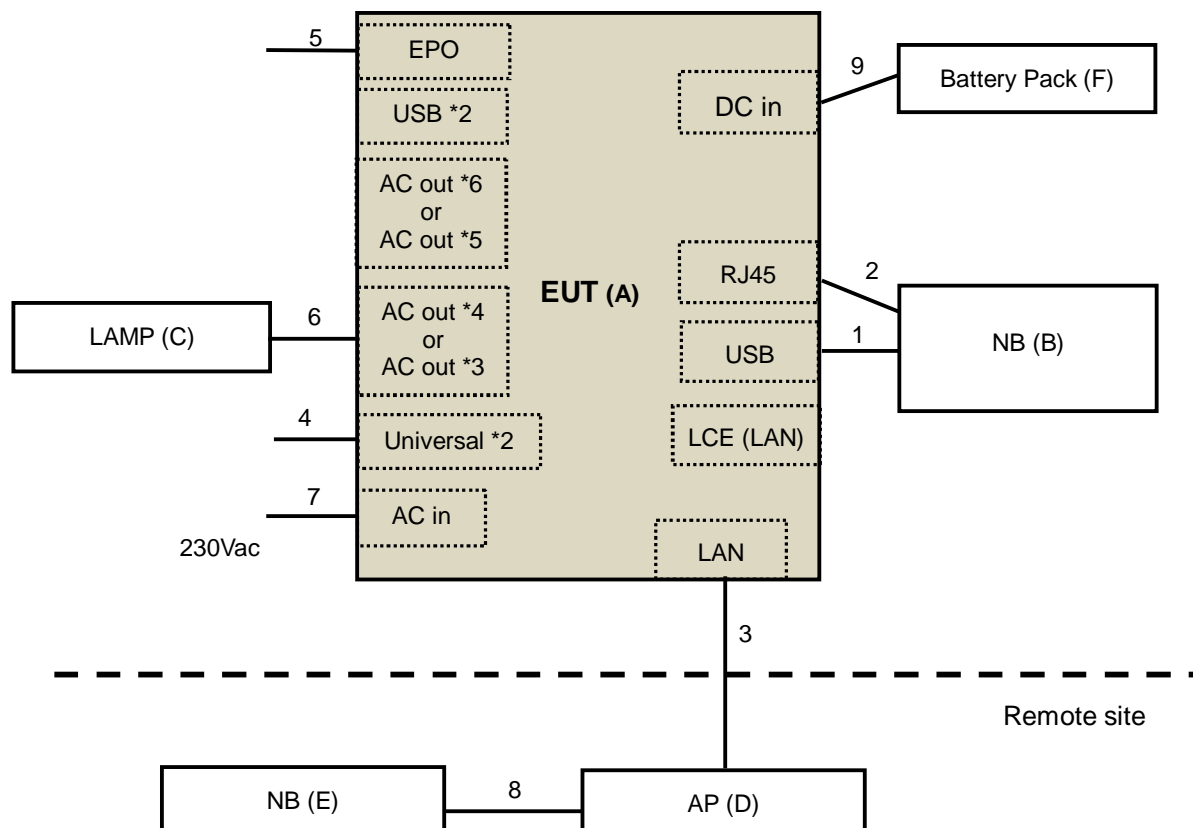
Harmonics, Flicker, Immunity tests:





ID	Product	Brand	Model No.	Serial No.	FCC ID	Remarks
A.	EUT		SRT3000RMXLW-IEC	QS1430242314	N/A	Supplied by client
			SRT2200RMXLI	QS1430242228		
B.	NOTEBOOK COMPUTER	DELL	PP04X	CN-0HN341-4864 3-845-5341	FCC DoC Approved	Supplied by client
C.	LAMP	N/A	N/A	N/A	N/A	Supplied by client
D.	AP	N/A	N/A	N/A	N/A	Supplied by client
E.	NOTEBOOK COMPUTER	DELL	PP04X	9LRVR1S	FCC DoC Approved	Provided by Lab
F.	Battery Pack <only for Mode 3>		SRT72RMBP	5A1430T02020	N/A	Supplied by client
	Battery Pack <only for Mode 2>		SRT96RMBP	5A1430T02143	N/A	Supplied by client

Note:

1. All power cords of the above support units are non-shielded (1.8m).
2. Items D~E acted as communication partners to transfer data.

ID	Descriptions	Qty.	Length (m)	Shielding (Yes/No)	Cores (Qty.)	Remarks
1.	USB cable	1	5.0	Y	0	Supplied by client
2.	RJ45 to RS232 cable	1	5.0	N	0	Supplied by client
3.	LAN cable	1	10	N	0	Provided by Lab
4.	Universal I/O cable	2	5.0	N	0	Supplied by client
5.	EPO cable	1	5.0	N	0	Supplied by client
6.	AC power cable <only for Mode 3>	4	1.8	N	0	Provided by Lab
	AC power cable <only for Mode 2>	3	1.8	N	0	Provided by Lab
7.	AC Power cable	1	2.0	N	0	Supplied by client
8.	LAN cable	1	1.0	N	0	Provided by Lab
9.	DC cable	1	1.8	N	0	Provided by Lab

Note: The core(s) is(are) originally attached to the cable(s).

4 EMISSION TEST

4.1 CONDUCTED EMISSION MEASUREMENT

4.1.1 LIMITS OF CONDUCTED EMISSION MEASUREMENT

FREQUENCY (MHz)	Category C1 (dBuV)		Category C2 (dBuV)	
	Quasi-peak	Average	Quasi-peak	Average
0.15 - 0.5	66 – 56 ¹⁾	56 - 46 ¹⁾	79	66
0.50 - 5.0	56	46	73	60
5.0 - 30.0	60	50	73	60

¹⁾ The limit decreases linearly with the logarithm of the frequency

- NOTE:**
- (1) The lower limit shall apply at the transition frequencies.
 - (2) The limit decreases in line with the logarithm of the frequency in the range of 0.15 to 0.50 MHz.



4.1.2 TEST INSTRUMENTS

Description & Manufacturer	Model No.	Serial No.	Cal. Date	Cal. Due
ROHDE & SCHWARZ TEST RECEIVER	ESCS 30	100292	Dec. 18, 2014	Dec. 17, 2015
ROHDE & SCHWARZ Artificial Mains Network (for EUT)	ESH2-Z5	100104	Dec. 04, 2014	Dec. 03, 2015
LISN With Adapter (for EUT)	AD10	C09Ada-001	Dec. 04, 2014	Dec. 03, 2015
ROHDE & SCHWARZ Artificial Mains Network (for peripherals)	ESH3-Z5	847265/023	Oct. 21, 2014	Oct. 20, 2015
SCHWARZBECK Artificial Mains Network (For EUT)	NNLK8129	8129229	May 08, 2014	May 07, 2015
Software	ADT_Cond_V7.3.7	NA	NA	NA
RF cable (JYEBAO)	5D-FB	Cable-C09.01	Feb. 24, 2015	Feb. 23, 2016
SUHNER Terminator (For ROHDE & SCHWARZ LISN)	65BNC-5001	E1-010789	May 20, 2014	May 19, 2015
ROHDE & SCHWARZ Artificial Mains Network (For TV EUT)	ESH3-Z5	100220	Nov. 20, 2014	Nov. 19, 2015
LISN With Adapter (for TV EUT)	100220	N/A	Nov. 20, 2014	Nov. 19, 2015

- Notes:
1. The calibration interval of the above test instruments is 12 months and the calibrations are traceable to NML/ROC and NIST/USA.
 2. The test was performed in Shielded Room No. 9.
 3. The VCCI Site Registration No. C-1312.
 4. Tested Date: May 6, 2015.

4.1.3 TEST PROCEDURE

- a. The EUT was placed 0.4 meters from the conducting wall of the shielded room with EUT being connected to the power mains through a line impedance stabilization network (LISN). Other support units were connected to the power mains through another LISN. The two LISNs provide 50 Ohm/ 50uH of coupling impedance for the measuring instrument.
- b. Both lines of the power mains connected to the EUT were checked for maximum conducted interference.
- c. The frequency range from 150 kHz to 30 MHz was searched. Emission levels under (Limit -20dB) were not recorded.

4.1.4 DEVIATION FROM TEST STANDARD

No deviation

4.1.5 TEST SETUP

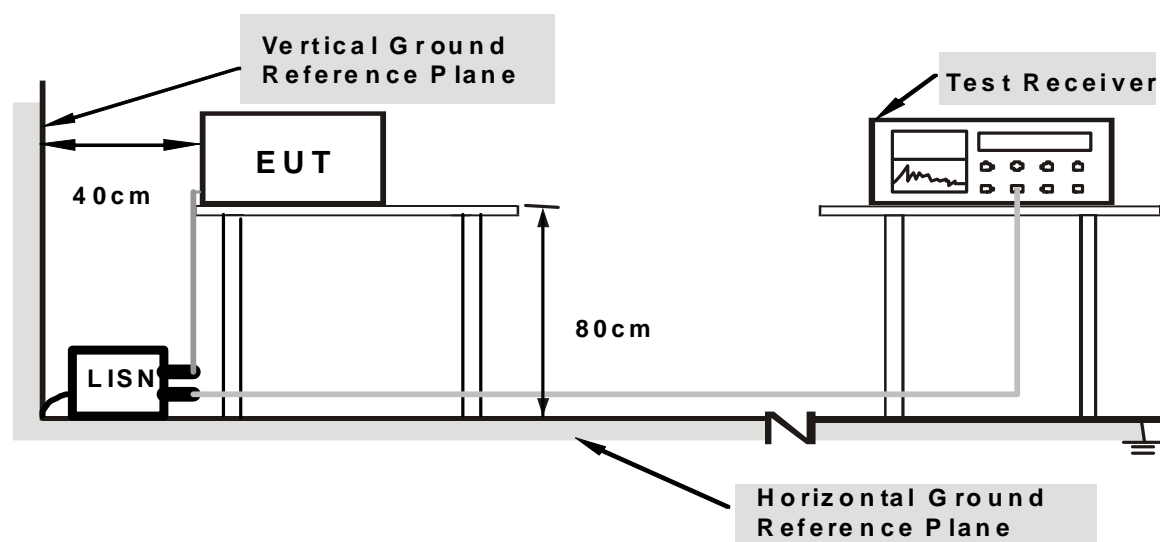

Note: Support units were connected to second LISN.

For the actual test configuration, please refer to the related item – Photographs of the Test Configuration.

4.1.6 EUT OPERATING CONDITIONS

- a. Connected NB with EUT via USB cable and RJ45 to RS232 cable.
- b. Set EUT under online mode or green mode or battery mode continuously.
- c. Turned on the power of all equipment.
- d. Notebook ran a test program to enable all functions.
- e. Notebook read and wrote messages from HDD and ext.HDD.
- f. Notebook sent “H” messages to panel and then panel displayed “H” patterns on its screen.
- g. EUT sent and received messages to/from Notebook (kept in a remote area) with Wireless Broadband Router via an UTP LAN cable (10m).
- h. Notebook run “short to ulSim-TreeView.BAT” via RS-232.
- i. Notebook keeps watch on Notebook’s device manager “APC UPS” via USB.
- j. Universal’s sensor keep watch on environment temperature.
- k. Notebook sent messages to printer, and then printer printed it out.
- l. After test check EPO function.
- m. Steps e-l were repeated.

4.1.7 TEST RESULTS (1)

Frequency Range	150kHz ~ 30MHz	Detector Function & Bandwidth	Quasi-Peak (QP) / Average (AV), 9kHz
Input Power	230Vac, 50Hz	Environmental Conditions	24°C, 66%RH
Tested by	Jary Huang		
Test Mode	Mode 1A		

Phase Of Power : Line (L)										
No	Frequency (MHz)	Correction Factor (dB)	Reading Value (dBuV)		Emission Level (dBuV)		Limit (dBuV)		Margin (dB)	
			Q.P.	AV.	Q.P.	AV.	Q.P.	AV.	Q.P.	AV.
1	0.15000	0.21	63.48	58.54	63.69	58.75	79.00	66.00	-15.31	-7.25
2	0.18125	0.21	55.07	50.99	55.28	51.20	79.00	66.00	-23.72	-14.80
3	6.03906	0.63	41.03	34.93	41.66	35.56	73.00	60.00	-31.34	-24.44
4	8.88281	0.72	51.16	45.83	51.88	46.55	73.00	60.00	-21.12	-13.45
5	14.10156	0.92	52.82	50.66	53.74	51.58	73.00	60.00	-19.26	-8.42
6	23.12763	1.12	46.09	44.04	47.21	45.16	73.00	60.00	-25.79	-14.84

Remarks:

1. Q.P. and AV. are abbreviations of quasi-peak and average individually.
2. The emission levels of other frequencies were very low against the limit.
3. Margin value = Emission level – Limit value
4. Correction factor = Insertion loss + Cable loss
5. Emission Level = Correction Factor + Reading Value

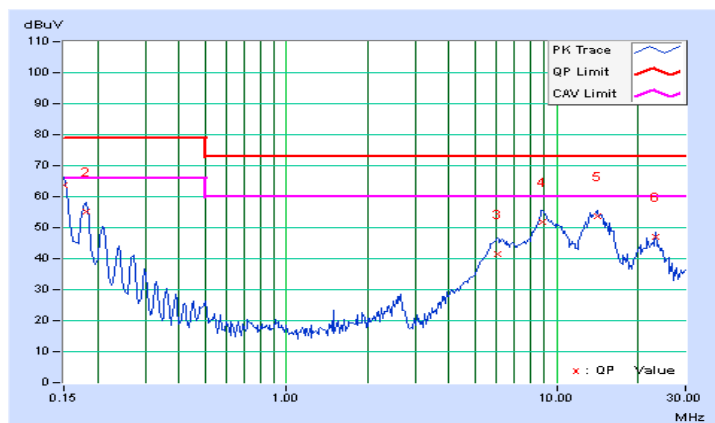



Frequency Range	150kHz ~ 30MHz	Detector Function & Bandwidth	Quasi-Peak (QP) / Average (AV), 9kHz
Input Power	230Vac, 50Hz	Environmental Conditions	24°C, 66%RH
Tested by	Jary Huang		
Test Mode	Mode 1A		

Phase Of Power : Neutral (N)										
No	Frequency (MHz)	Correction Factor (dB)	Reading Value (dBUV)		Emission Level (dBUV)		Limit (dBUV)		Margin (dB)	
			Q.P.	AV.	Q.P.	AV.	Q.P.	AV.	Q.P.	AV.
1	0.15128	0.21	51.64	46.03	51.85	46.24	79.00	66.00	-27.15	-19.76
2	0.18253	0.22	46.83	43.94	47.05	44.16	79.00	66.00	-31.95	-21.84
3	2.64063	0.50	26.34	20.45	26.84	20.95	73.00	60.00	-46.16	-39.05
4	6.19141	0.63	41.55	35.46	42.18	36.09	73.00	60.00	-30.82	-23.91
5	8.82422	0.71	49.72	44.28	50.43	44.99	73.00	60.00	-22.57	-15.01
6	13.80078	0.83	54.34	52.68	55.17	53.51	73.00	60.00	-17.83	-6.49

Remarks:

1. Q.P. and AV. are abbreviations of quasi-peak and average individually.
2. The emission levels of other frequencies were very low against the limit.
3. Margin value = Emission level – Limit value
4. Correction factor = Insertion loss + Cable loss
5. Emission Level = Correction Factor + Reading Value

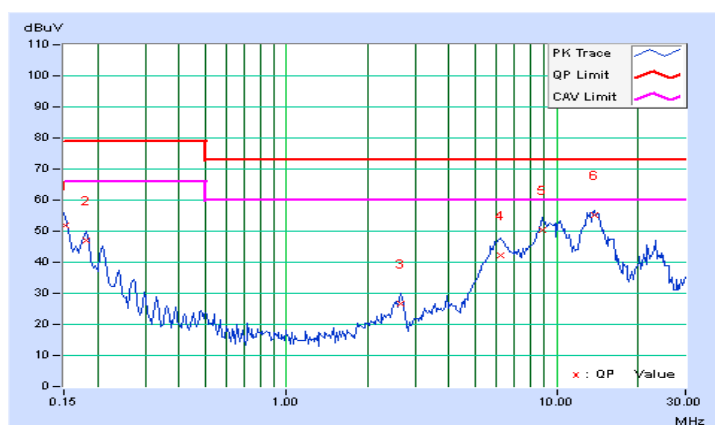

4.1.8 TEST RESULTS (2)

Frequency Range	150kHz ~ 30MHz	Detector Function & Bandwidth	Quasi-Peak (QP) / Average (AV), 9kHz
Input Power	230Vac, 50Hz	Environmental Conditions	24°C, 66%RH
Tested by	Jary Huang		
Test Mode	Mode 1B		

Phase Of Power : Line (L)										
No	Frequency (MHz)	Correction Factor (dB)	Reading Value (dBuV)		Emission Level (dBuV)		Limit (dBuV)		Margin (dB)	
			Q.P.	AV.	Q.P.	AV.	Q.P.	AV.	Q.P.	AV.
1	0.15128	0.21	62.58	57.88	62.79	58.09	79.00	66.00	-16.21	-7.91
2	0.18125	0.21	54.59	50.37	54.80	50.58	79.00	66.00	-24.20	-15.42
3	2.49219	0.48	26.35	22.17	26.83	22.65	73.00	60.00	-46.17	-37.35
4	8.90625	0.72	52.22	46.85	52.94	47.57	73.00	60.00	-20.06	-12.43
5	14.10156	0.92	53.21	50.74	54.13	51.66	73.00	60.00	-18.87	-8.34
6	23.12891	1.12	45.73	42.93	46.85	44.05	73.00	60.00	-26.15	-15.95

Remarks:

1. Q.P. and AV. are abbreviations of quasi-peak and average individually.
2. The emission levels of other frequencies were very low against the limit.
3. Margin value = Emission level – Limit value
4. Correction factor = Insertion loss + Cable loss
5. Emission Level = Correction Factor + Reading Value

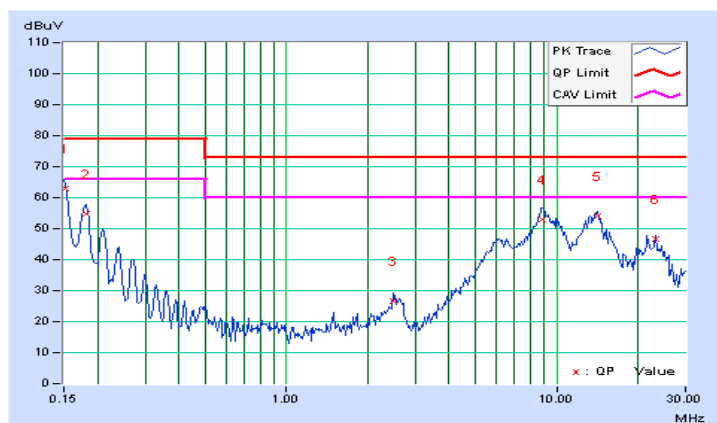



Frequency Range	150kHz ~ 30MHz	Detector Function & Bandwidth	Quasi-Peak (QP) / Average (AV), 9kHz
Input Power	230Vac, 50Hz	Environmental Conditions	24°C, 66%RH
Tested by	Jary Huang		
Test Mode	Mode 1B		

Phase Of Power : Neutral (N)										
No	Frequency (MHz)	Correction Factor (dB)	Reading Value (dBUV)		Emission Level (dBUV)		Limit (dBUV)		Margin (dB)	
			Q.P.	AV.	Q.P.	AV.	Q.P.	AV.	Q.P.	AV.
1	0.15000	0.21	51.39	45.92	51.60	46.13	79.00	66.00	-27.40	-19.87
2	0.18253	0.22	46.75	44.06	46.97	44.28	79.00	66.00	-32.03	-21.72
3	6.27344	0.63	41.20	34.98	41.83	35.61	73.00	60.00	-31.17	-24.39
4	9.10156	0.71	45.35	39.58	46.06	40.29	73.00	60.00	-26.94	-19.71
5	13.50128	0.82	54.56	52.49	55.38	53.31	73.00	60.00	-17.62	-6.69
6	23.12500	0.81	44.50	42.31	45.31	43.12	73.00	60.00	-27.69	-16.88

Remarks:

1. Q.P. and AV. are abbreviations of quasi-peak and average individually.
2. The emission levels of other frequencies were very low against the limit.
3. Margin value = Emission level – Limit value
4. Correction factor = Insertion loss + Cable loss
5. Emission Level = Correction Factor + Reading Value

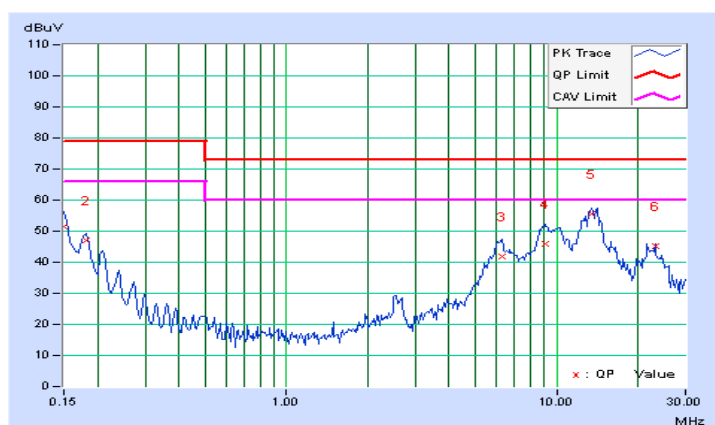

4.1.9 TEST RESULTS (3)

Frequency Range	150kHz ~ 30MHz	Detector Function & Bandwidth	Quasi-Peak (QP) / Average (AV), 9kHz
Input Power	230Vac, 50Hz	Environmental Conditions	24°C, 66%RH
Tested by	Jary Huang		
Test Mode	Mode 1C		

Phase Of Power : Line (L)										
No	Frequency (MHz)	Correction Factor (dB)	Reading Value (dBuV)		Emission Level (dBuV)		Limit (dBuV)		Margin (dB)	
			Q.P.	AV.	Q.P.	AV.	Q.P.	AV.	Q.P.	AV.
1	0.16087	0.21	39.15	36.48	39.36	36.69	79.00	66.00	-39.64	-29.31
2	1.12109	0.38	34.33	32.71	34.71	33.09	73.00	60.00	-38.29	-26.91
3	2.32031	0.48	49.69	49.03	50.17	49.51	73.00	60.00	-22.83	-10.49
4	8.73438	0.72	42.64	37.61	43.36	38.33	73.00	60.00	-29.64	-21.67
5	14.16016	0.93	44.35	38.19	45.28	39.12	73.00	60.00	-27.72	-20.88
6	23.12755	1.12	46.11	44.06	47.23	45.18	73.00	60.00	-25.77	-14.82

Remarks:

1. Q.P. and AV. are abbreviations of quasi-peak and average individually.
2. The emission levels of other frequencies were very low against the limit.
3. Margin value = Emission level – Limit value
4. Correction factor = Insertion loss + Cable loss
5. Emission Level = Correction Factor + Reading Value

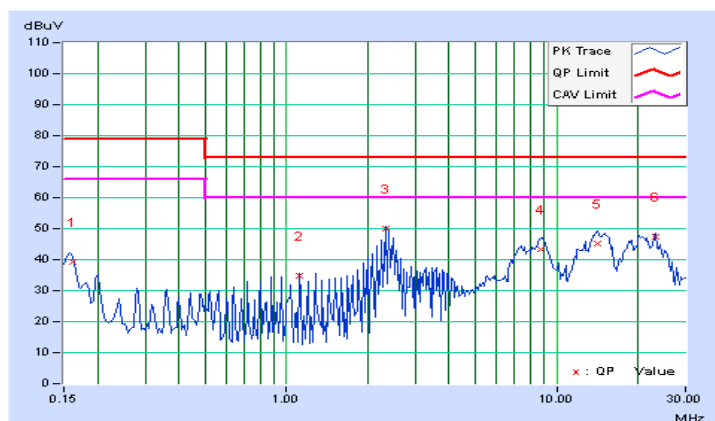



Frequency Range	150kHz ~ 30MHz	Detector Function & Bandwidth	Quasi-Peak (QP) / Average (AV), 9kHz
Input Power	230Vac, 50Hz	Environmental Conditions	24°C, 66%RH
Tested by	Jary Huang		
Test Mode	Mode 1C		

Phase Of Power : Neutral (N)										
No	Frequency (MHz)	Correction Factor (dB)	Reading Value (dBUV)		Emission Level (dBUV)		Limit (dBUV)		Margin (dB)	
			Q.P.	AV.	Q.P.	AV.	Q.P.	AV.	Q.P.	AV.
1	0.16172	0.21	39.87	36.72	40.08	36.93	79.00	66.00	-38.92	-29.07
2	0.88047	0.36	33.06	30.55	33.42	30.91	73.00	60.00	-39.58	-29.09
3	2.40099	0.49	54.82	51.52	55.31	52.01	73.00	60.00	-17.69	-7.99
4	7.19922	0.66	45.08	38.09	45.74	38.75	73.00	60.00	-27.26	-21.25
5	13.35938	0.82	45.52	40.51	46.34	41.33	73.00	60.00	-26.66	-18.67
6	19.04297	0.93	39.36	34.11	40.29	35.04	73.00	60.00	-32.71	-24.96

Remarks:

1. Q.P. and AV. are abbreviations of quasi-peak and average individually.
2. The emission levels of other frequencies were very low against the limit.
3. Margin value = Emission level – Limit value
4. Correction factor = Insertion loss + Cable loss
5. Emission Level = Correction Factor + Reading Value

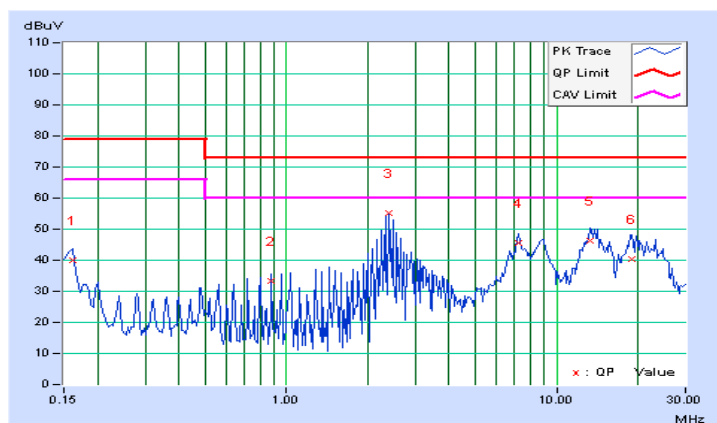

4.1.10 TEST RESULTS (4)

Frequency Range	150kHz ~ 30MHz	Detector Function & Bandwidth	Quasi-Peak (QP) / Average (AV), 9kHz
Input Power	208Vac, 50Hz	Environmental Conditions	24°C, 66%RH
Tested by	Jary Huang		
Test Mode	Mode 2A		

Phase Of Power : Line (L)										
No	Frequency (MHz)	Correction Factor (dB)	Reading Value (dBuV)		Emission Level (dBuV)		Limit (dBuV)		Margin (dB)	
			Q.P.	AV.	Q.P.	AV.	Q.P.	AV.	Q.P.	AV.
1	0.15000	0.21	63.59	58.66	63.80	58.87	79.00	66.00	-15.20	-7.13
2	0.18125	0.21	55.09	51.15	55.30	51.36	79.00	66.00	-23.70	-14.64
3	6.08594	0.63	41.34	35.45	41.97	36.08	73.00	60.00	-31.03	-23.92
4	8.88281	0.72	50.92	45.53	51.64	46.25	73.00	60.00	-21.36	-13.75
5	14.49219	0.94	52.18	48.36	53.12	49.30	73.00	60.00	-19.88	-10.70
6	23.12891	1.12	45.59	42.93	46.71	44.05	73.00	60.00	-26.29	-15.95

Remarks:

1. Q.P. and AV. are abbreviations of quasi-peak and average individually.
2. The emission levels of other frequencies were very low against the limit.
3. Margin value = Emission level – Limit value
4. Correction factor = Insertion loss + Cable loss
5. Emission Level = Correction Factor + Reading Value

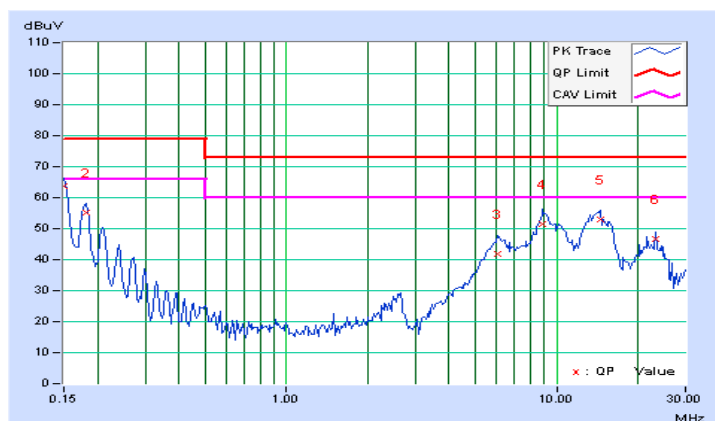



Frequency Range	150kHz ~ 30MHz	Detector Function & Bandwidth	Quasi-Peak (QP) / Average (AV), 9kHz
Input Power	208Vac, 50Hz	Environmental Conditions	24°C, 66%RH
Tested by	Jary Huang		
Test Mode	Mode 2A		

Phase Of Power : Neutral (N)										
No	Frequency (MHz)	Correction Factor (dB)	Reading Value (dBuV)		Emission Level (dBuV)		Limit (dBuV)		Margin (dB)	
			Q.P.	AV.	Q.P.	AV.	Q.P.	AV.	Q.P.	AV.
1	0.15000	0.21	50.66	46.22	50.87	46.43	79.00	66.00	-28.13	-19.57
2	0.18253	0.22	46.37	42.93	46.59	43.15	79.00	66.00	-32.41	-22.85
3	6.12500	0.63	42.03	35.99	42.66	36.62	73.00	60.00	-30.34	-23.38
4	8.91016	0.71	50.65	45.28	51.36	45.99	73.00	60.00	-21.64	-14.01
5	13.53125	0.82	53.71	51.67	54.53	52.49	73.00	60.00	-18.47	-7.51
6	23.12773	0.81	45.20	43.09	46.01	43.90	73.00	60.00	-26.99	-16.10

Remarks:

1. Q.P. and AV. are abbreviations of quasi-peak and average individually.
2. The emission levels of other frequencies were very low against the limit.
3. Margin value = Emission level – Limit value
4. Correction factor = Insertion loss + Cable loss
5. Emission Level = Correction Factor + Reading Value

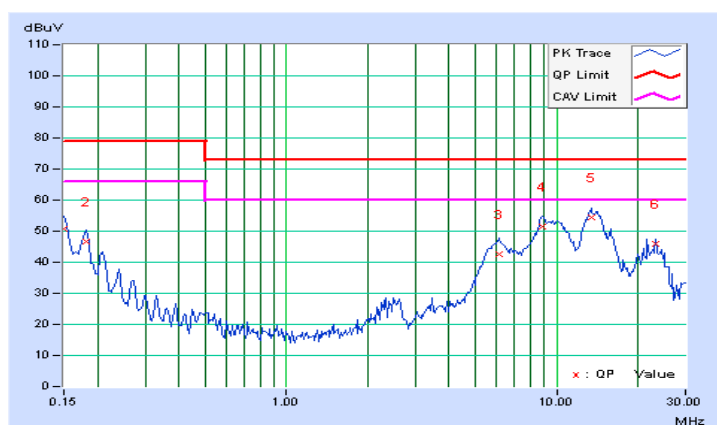

4.1.11 TEST RESULTS (5)

Frequency Range	150kHz ~ 30MHz	Detector Function & Bandwidth	Quasi-Peak (QP) / Average (AV), 9kHz
Input Power	208Vac, 50Hz	Environmental Conditions	24°C, 66%RH
Tested by	Jary Huang		
Test Mode	Mode 2B		

Phase Of Power : Line (L)										
No	Frequency (MHz)	Correction Factor (dB)	Reading Value (dBuV)		Emission Level (dBuV)		Limit (dBuV)		Margin (dB)	
			Q.P.	AV.	Q.P.	AV.	Q.P.	AV.	Q.P.	AV.
1	0.15000	0.21	63.63	57.02	63.84	57.23	79.00	66.00	-15.16	-8.77
2	0.18125	0.21	55.91	51.79	56.12	52.00	79.00	66.00	-22.88	-14.00
3	2.67188	0.49	23.76	17.56	24.25	18.05	73.00	60.00	-48.75	-41.95
4	8.89844	0.72	53.54	47.91	54.26	48.63	73.00	60.00	-18.74	-11.37
5	14.10156	0.92	54.39	51.10	55.31	52.02	73.00	60.00	-17.69	-7.98
6	23.12891	1.12	45.73	42.93	46.85	44.05	73.00	60.00	-26.15	-15.95

Remarks:

1. Q.P. and AV. are abbreviations of quasi-peak and average individually.
2. The emission levels of other frequencies were very low against the limit.
3. Margin value = Emission level – Limit value
4. Correction factor = Insertion loss + Cable loss
5. Emission Level = Correction Factor + Reading Value

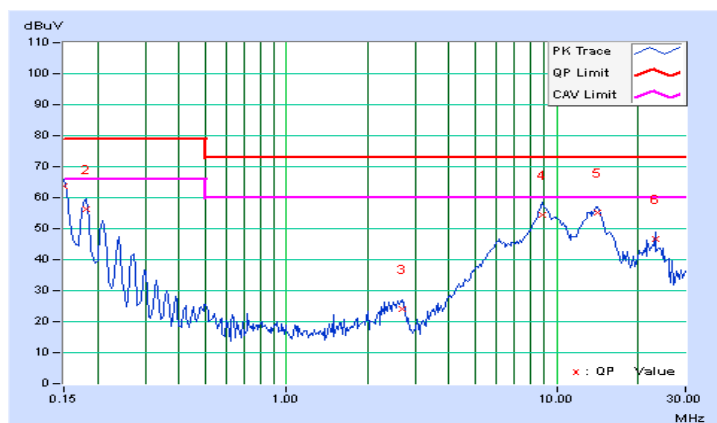



Frequency Range	150kHz ~ 30MHz	Detector Function & Bandwidth	Quasi-Peak (QP) / Average (AV), 9kHz
Input Power	208Vac, 50Hz	Environmental Conditions	24°C, 66%RH
Tested by	Jary Huang		
Test Mode	Mode 2B		

Phase Of Power : Neutral (N)										
No	Frequency (MHz)	Correction Factor (dB)	Reading Value (dBUV)		Emission Level (dBUV)		Limit (dBUV)		Margin (dB)	
			Q.P.	AV.	Q.P.	AV.	Q.P.	AV.	Q.P.	AV.
1	0.15000	0.21	51.26	45.92	51.47	46.13	79.00	66.00	-27.53	-19.87
2	0.18125	0.22	47.20	43.62	47.42	43.84	79.00	66.00	-31.58	-22.16
3	2.67188	0.50	25.06	18.16	25.56	18.66	73.00	60.00	-47.44	-41.34
4	6.21094	0.63	41.50	35.00	42.13	35.63	73.00	60.00	-30.87	-24.37
5	13.80078	0.83	55.12	51.30	55.95	52.13	73.00	60.00	-17.05	-7.87
6	23.12500	0.81	44.37	42.43	45.18	43.24	73.00	60.00	-27.82	-16.76

Remarks:

1. Q.P. and AV. are abbreviations of quasi-peak and average individually.
2. The emission levels of other frequencies were very low against the limit.
3. Margin value = Emission level – Limit value
4. Correction factor = Insertion loss + Cable loss
5. Emission Level = Correction Factor + Reading Value

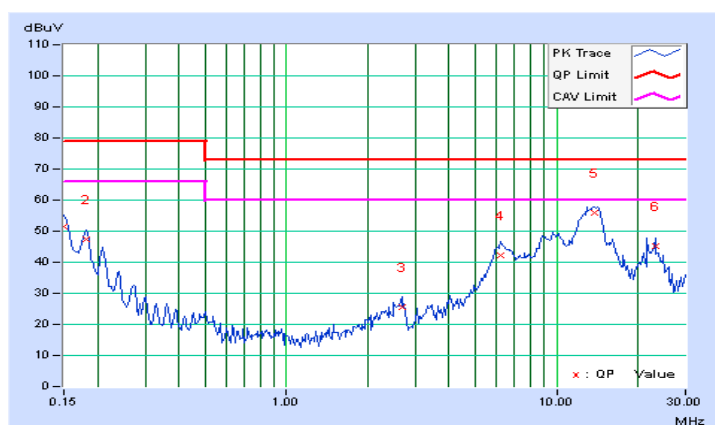

4.1.12 TEST RESULTS (6)

Frequency Range	150kHz ~ 30MHz	Detector Function & Bandwidth	Quasi-Peak (QP) / Average (AV), 9kHz
Input Power	208Vac, 50Hz	Environmental Conditions	24°C, 66%RH
Tested by	Jary Huang		
Test Mode	Mode 2C		

Phase Of Power : Line (L)										
No	Frequency (MHz)	Correction Factor (dB)	Reading Value (dBuV)		Emission Level (dBuV)		Limit (dBuV)		Margin (dB)	
			Q.P.	AV.	Q.P.	AV.	Q.P.	AV.	Q.P.	AV.
1	0.16163	0.21	37.35	34.56	37.56	34.77	79.00	66.00	-41.44	-31.23
2	1.12109	0.38	33.67	32.15	34.05	32.53	73.00	60.00	-38.95	-27.47
3	2.32031	0.48	49.65	49.37	50.13	49.85	73.00	60.00	-22.87	-10.15
4	8.87500	0.72	43.85	38.84	44.57	39.56	73.00	60.00	-28.43	-20.44
5	14.00000	0.92	43.81	36.95	44.73	37.87	73.00	60.00	-28.27	-22.13
6	23.12500	1.12	45.61	43.19	46.73	44.31	73.00	60.00	-26.27	-15.69

Remarks:

1. Q.P. and AV. are abbreviations of quasi-peak and average individually.
2. The emission levels of other frequencies were very low against the limit.
3. Margin value = Emission level – Limit value
4. Correction factor = Insertion loss + Cable loss
5. Emission Level = Correction Factor + Reading Value

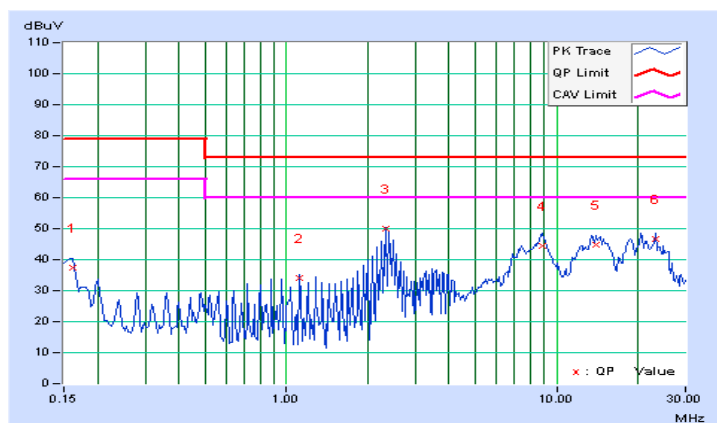



Frequency Range	150kHz ~ 30MHz	Detector Function & Bandwidth	Quasi-Peak (QP) / Average (AV), 9kHz
Input Power	208Vac, 50Hz	Environmental Conditions	24°C, 66%RH
Tested by	Jary Huang		
Test Mode	Mode 2C		

Phase Of Power : Neutral (N)										
No	Frequency (MHz)	Correction Factor (dB)	Reading Value (dBuV)		Emission Level (dBuV)		Limit (dBuV)		Margin (dB)	
			Q.P.	AV.	Q.P.	AV.	Q.P.	AV.	Q.P.	AV.
1	0.15781	0.21	37.25	33.58	37.46	33.79	79.00	66.00	-41.54	-32.21
2	0.88047	0.36	28.75	27.39	29.11	27.75	73.00	60.00	-43.89	-32.25
3	2.32031	0.49	50.01	49.69	50.50	50.18	73.00	60.00	-22.50	-9.82
4	7.29297	0.66	38.40	33.32	39.06	33.98	73.00	60.00	-33.94	-26.02
5	13.35938	0.82	45.46	40.31	46.28	41.13	73.00	60.00	-26.72	-18.87
6	23.12891	0.81	44.36	42.03	45.17	42.84	73.00	60.00	-27.83	-17.16

Remarks:

1. Q.P. and AV. are abbreviations of quasi-peak and average individually.
2. The emission levels of other frequencies were very low against the limit.
3. Margin value = Emission level – Limit value
4. Correction factor = Insertion loss + Cable loss
5. Emission Level = Correction Factor + Reading Value

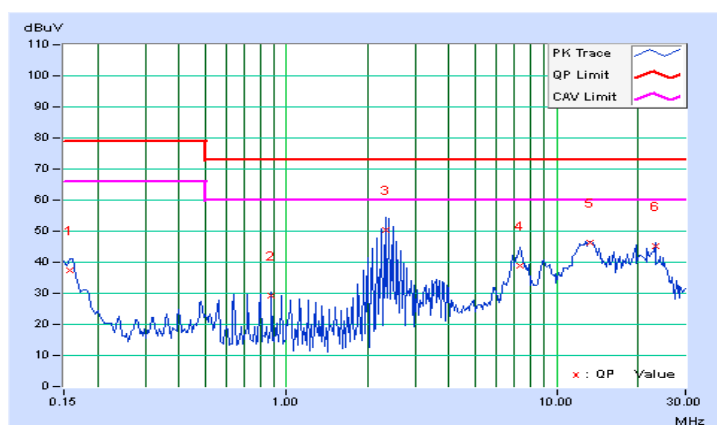

4.1.13 TEST RESULTS (7)

Frequency Range	150kHz ~ 30MHz	Detector Function & Bandwidth	Quasi-Peak (QP) / Average (AV), 9kHz
Input Power	230Vac, 50Hz	Environmental Conditions	24°C, 66%RH
Tested by	Jary Huang		
Test Mode	Mode 3A		

Phase Of Power : Line (L)										
No	Frequency (MHz)	Correction Factor (dB)	Reading Value (dBUV)		Emission Level (dBUV)		Limit (dBUV)		Margin (dB)	
			Q.P.	AV.	Q.P.	AV.	Q.P.	AV.	Q.P.	AV.
1	0.15000	0.21	61.61	56.63	61.82	56.84	79.00	66.00	-17.18	-9.16
2	0.18124	0.21	53.66	49.70	53.87	49.91	79.00	66.00	-25.13	-16.09
3	0.50156	0.29	34.63	28.81	34.92	29.10	73.00	60.00	-38.08	-30.90
4	5.88281	0.62	40.94	35.11	41.56	35.73	73.00	60.00	-31.44	-24.27
5	8.73047	0.72	52.55	47.02	53.27	47.74	73.00	60.00	-19.73	-12.26
6	13.98047	0.92	51.71	48.52	52.63	49.44	73.00	60.00	-20.37	-10.56
7	23.12763	1.12	44.50	42.27	45.62	43.39	73.00	60.00	-27.38	-16.61

Remarks:

1. Q.P. and AV. are abbreviations of quasi-peak and average individually.
2. The emission levels of other frequencies were very low against the limit.
3. Margin value = Emission level – Limit value
4. Correction factor = Insertion loss + Cable loss
5. Emission Level = Correction Factor + Reading Value

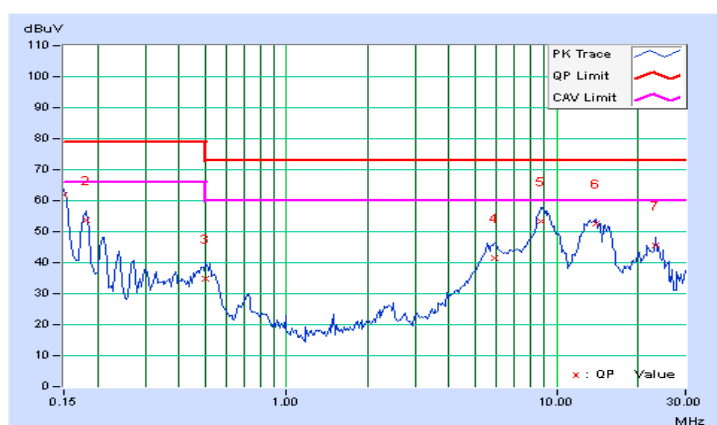



Frequency Range	150kHz ~ 30MHz	Detector Function & Bandwidth	Quasi-Peak (QP) / Average (AV), 9kHz
Input Power	230Vac, 50Hz	Environmental Conditions	24°C, 66%RH
Tested by	Jary Huang		
Test Mode	Mode 3A		

Phase Of Power : Neutral (N)										
No	Frequency (MHz)	Correction Factor (dB)	Reading Value (dBUV)		Emission Level (dBUV)		Limit (dBUV)		Margin (dB)	
			Q.P.	AV.	Q.P.	AV.	Q.P.	AV.	Q.P.	AV.
1	0.15128	0.21	51.86	47.30	52.07	47.51	79.00	66.00	-26.93	-18.49
2	0.18125	0.22	47.60	42.97	47.82	43.19	79.00	66.00	-31.18	-22.81
3	0.52500	0.30	33.85	27.26	34.15	27.56	73.00	60.00	-38.85	-32.44
4	6.00000	0.63	42.45	36.21	43.08	36.84	73.00	60.00	-29.92	-23.16
5	8.91406	0.71	51.19	45.93	51.90	46.64	73.00	60.00	-21.10	-13.36
6	13.71094	0.83	54.63	52.96	55.46	53.79	73.00	60.00	-17.54	-6.21

Remarks:

1. Q.P. and AV. are abbreviations of quasi-peak and average individually.
2. The emission levels of other frequencies were very low against the limit.
3. Margin value = Emission level – Limit value
4. Correction factor = Insertion loss + Cable loss
5. Emission Level = Correction Factor + Reading Value

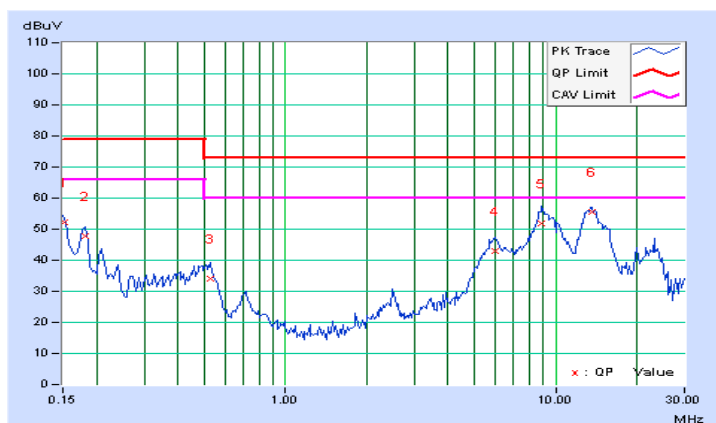

4.1.14 TEST RESULTS (8)

Frequency Range	150kHz ~ 30MHz	Detector Function & Bandwidth	Quasi-Peak (QP) / Average (AV), 9kHz
Input Power	230Vac, 50Hz	Environmental Conditions	24°C, 66%RH
Tested by	Jary Huang		
Test Mode	Mode 3B		

Phase Of Power : Line (L)										
No	Frequency (MHz)	Correction Factor (dB)	Reading Value (dBuV)		Emission Level (dBuV)		Limit (dBuV)		Margin (dB)	
			Q.P.	AV.	Q.P.	AV.	Q.P.	AV.	Q.P.	AV.
1	0.15128	0.21	61.66	56.86	61.87	57.07	79.00	66.00	-17.13	-8.93
2	0.18116	0.21	53.92	49.66	54.13	49.87	79.00	66.00	-24.87	-16.13
3	0.50156	0.29	34.59	28.65	34.88	28.94	73.00	60.00	-38.12	-31.06
4	2.49219	0.48	27.66	22.67	28.14	23.15	73.00	60.00	-44.86	-36.85
5	8.70703	0.72	52.13	46.66	52.85	47.38	73.00	60.00	-20.15	-12.62
6	13.74218	0.91	53.52	51.45	54.43	52.36	73.00	60.00	-18.57	-7.64

Remarks:

1. Q.P. and AV. are abbreviations of quasi-peak and average individually.
2. The emission levels of other frequencies were very low against the limit.
3. Margin value = Emission level – Limit value
4. Correction factor = Insertion loss + Cable loss
5. Emission Level = Correction Factor + Reading Value

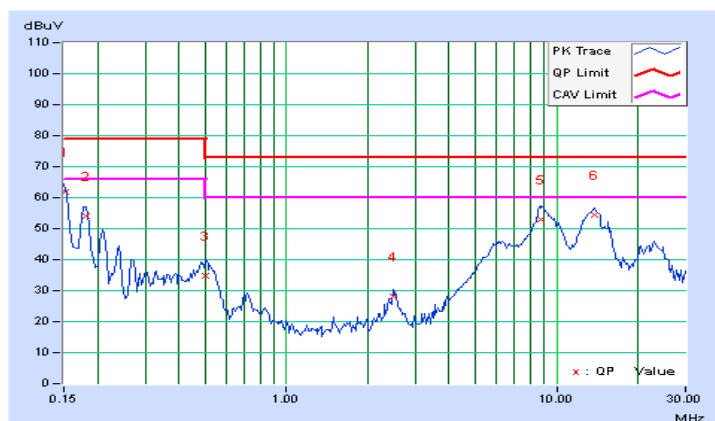



Frequency Range	150kHz ~ 30MHz	Detector Function & Bandwidth	Quasi-Peak (QP) / Average (AV), 9kHz
Input Power	230Vac, 50Hz	Environmental Conditions	24°C, 66%RH
Tested by	Jary Huang		
Test Mode	Mode 3B		

Phase Of Power : Neutral (N)										
No	Frequency (MHz)	Correction Factor (dB)	Reading Value (dBuV)		Emission Level (dBuV)		Limit (dBuV)		Margin (dB)	
			Q.P.	AV.	Q.P.	AV.	Q.P.	AV.	Q.P.	AV.
1	0.15000	0.21	50.70	45.81	50.91	46.02	79.00	66.00	-28.09	-19.98
2	0.18125	0.22	46.94	43.11	47.16	43.33	79.00	66.00	-31.84	-22.67
3	0.50156	0.30	34.76	28.67	35.06	28.97	73.00	60.00	-37.94	-31.03
4	6.00391	0.63	40.96	34.58	41.59	35.21	73.00	60.00	-31.41	-24.79
5	9.66016	0.73	48.37	44.16	49.10	44.89	73.00	60.00	-23.90	-15.11
6	13.23047	0.81	54.27	52.47	55.08	53.28	73.00	60.00	-17.92	-6.72

Remarks:

1. Q.P. and AV. are abbreviations of quasi-peak and average individually.
2. The emission levels of other frequencies were very low against the limit.
3. Margin value = Emission level – Limit value
4. Correction factor = Insertion loss + Cable loss
5. Emission Level = Correction Factor + Reading Value

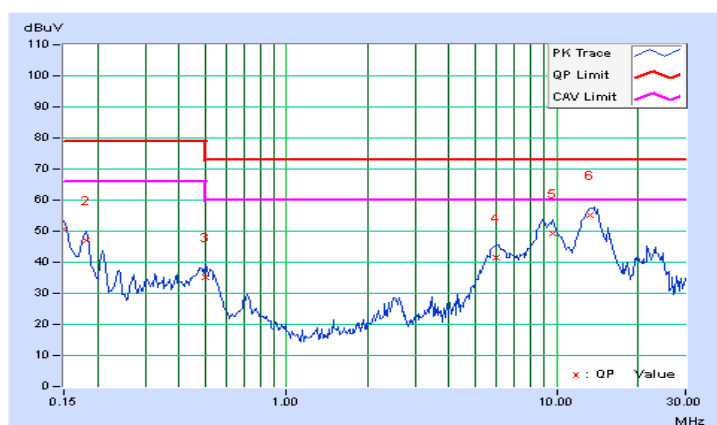

4.1.15 TEST RESULTS (9)

Frequency Range	150kHz ~ 30MHz	Detector Function & Bandwidth	Quasi-Peak (QP) / Average (AV), 9kHz
Input Power	230Vac, 50Hz	Environmental Conditions	24°C, 66%RH
Tested by	Jary Huang		
Test Mode	Mode 3C		

Phase Of Power : Line (L)										
No	Frequency (MHz)	Correction Factor (dB)	Reading Value (dBuV)		Emission Level (dBuV)		Limit (dBuV)		Margin (dB)	
			Q.P.	AV.	Q.P.	AV.	Q.P.	AV.	Q.P.	AV.
1	0.16163	0.21	37.65	34.88	37.86	35.09	79.00	66.00	-41.14	-30.91
2	0.51719	0.29	35.99	30.52	36.28	30.81	73.00	60.00	-36.72	-29.19
3	2.40095	0.48	50.31	49.43	50.79	49.91	73.00	60.00	-22.21	-10.09
4	8.86719	0.72	42.50	37.51	43.22	38.23	73.00	60.00	-29.78	-21.77
5	13.76172	0.91	45.06	37.67	45.97	38.58	73.00	60.00	-27.03	-21.42
6	19.84239	1.13	42.59	35.43	43.72	36.56	73.00	60.00	-29.28	-23.44

Remarks:

1. Q.P. and AV. are abbreviations of quasi-peak and average individually.
2. The emission levels of other frequencies were very low against the limit.
3. Margin value = Emission level – Limit value
4. Correction factor = Insertion loss + Cable loss
5. Emission Level = Correction Factor + Reading Value

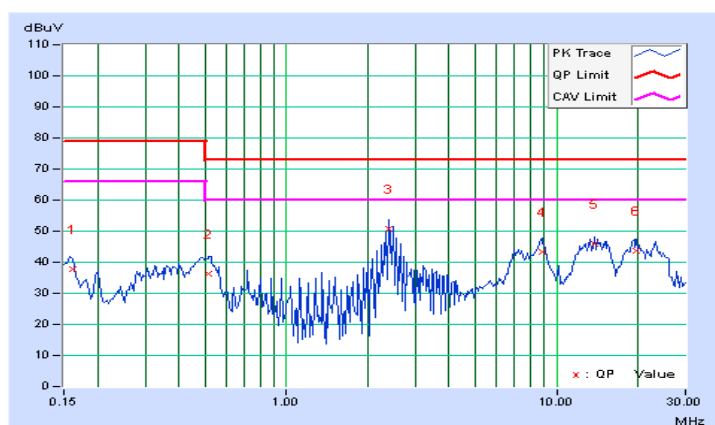



Frequency Range	150kHz ~ 30MHz	Detector Function & Bandwidth	Quasi-Peak (QP) / Average (AV), 9kHz
Input Power	230Vac, 50Hz	Environmental Conditions	24°C, 66%RH
Tested by	Jary Huang		
Test Mode	Mode 3C		

Phase Of Power : Neutral (N)										
No	Frequency (MHz)	Correction Factor (dB)	Reading Value (dBuV)		Emission Level (dBuV)		Limit (dBuV)		Margin (dB)	
			Q.P.	AV.	Q.P.	AV.	Q.P.	AV.	Q.P.	AV.
1	0.16044	0.21	37.92	34.64	38.13	34.85	79.00	66.00	-40.87	-31.15
2	0.52109	0.30	37.05	31.46	37.35	31.76	73.00	60.00	-35.65	-28.24
3	2.40030	0.49	50.64	50.34	51.13	50.83	73.00	60.00	-21.87	-9.17
4	8.71484	0.70	42.36	37.33	43.06	38.03	73.00	60.00	-29.94	-21.97
5	13.60156	0.82	46.50	40.95	47.32	41.77	73.00	60.00	-25.68	-18.23
6	20.56250	0.93	42.45	34.30	43.38	35.23	73.00	60.00	-29.62	-24.77

Remarks:

1. Q.P. and AV. are abbreviations of quasi-peak and average individually.
2. The emission levels of other frequencies were very low against the limit.
3. Margin value = Emission level – Limit value
4. Correction factor = Insertion loss + Cable loss
5. Emission Level = Correction Factor + Reading Value

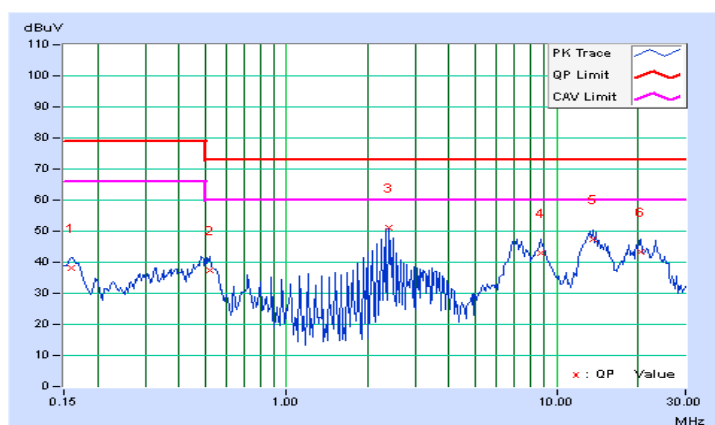

4.2 CONDUCTED EMISSION MEASUREMENT AT TELECOMMUNICATION PORTS

4.2.1 LIMIT OF CONDUCTED COMMON MODE DISTURBANCE AT TELECOMMUNICATION PORTS

TEST STANDARD: EN 55022 FOR CLASS A EQUIPMENT

FREQUENCY (MHz)	Voltage Limit (dBuV)		Current Limit (dBuA)	
	Quasi-peak	Average	Quasi-peak	Average
0.15 - 0.5	97 – 87	84 - 74	53 – 43	40 – 30
0.5 - 30.0	87	74	43	30

FOR CLASS B EQUIPMENT

FREQUENCY (MHz)	Voltage Limit (dBuV)		Current Limit (dBuA)	
	Quasi-peak	Average	Quasi-peak	Average
0.15 - 0.5	84 - 74	74 - 64	40 – 30	30 – 20
0.5 - 30.0	74	64	30	20

NOTE: (1) The limits decrease linearly with the logarithm of the frequency in the range 0.15 MHz to 0.5 MHz.



4.2.2 TEST INSTRUMENTS

Description & Manufacturer	Model No.	Serial No.	Cal. Date	Cal. Due
ROHDE & SCHWARZ TEST RECEIVER	ESCS 30	100292	Dec. 18, 2014	Dec. 17, 2015
ROHDE & SCHWARZ Artificial Mains Network (for EUT)	ESH2-Z5	100104	Dec. 04, 2014	Dec. 03, 2015
LISN With Adapter (for EUT)	AD10	C09Ada-001	Dec. 04, 2014	Dec. 03, 2015
ROHDE & SCHWARZ Artificial Mains Network (for peripherals)	ESH3-Z5	847265/023	Oct. 21, 2014	Oct. 20, 2015
Software	ADT_Cond_V7.3.7	NA	NA	NA
Software	ADT_ISN_V7.3.7	NA	NA	NA
RF cable (JYEBAO)	5D-FB	Cable-C09.01	Feb. 24, 2015	Feb. 23, 2016
SUHNER Terminator (For ROHDE & SCHWARZ LISN)	65BNC-5001	E1-010789	May 20, 2014	May 19, 2015
FCC ISN	F-071115-1057-1	20650	Jan. 22, 2015	Jan. 21, 2016
FCC ISN	F-071115-1057-1	20651	Feb. 09, 2015	Feb. 08, 2016
FCC ISN	F-071115-1057-1	20652	Jan. 12, 2015	Jan. 11, 2016

- Notes: 1. The calibration interval of the above test instruments is 12 months and the calibrations are traceable to NML/ROC and NIST/USA.
 2. The test was performed in Shielded Room No. 9.
 3. The VCCI Site Registration No. T-1587
 4. Tested Date: May 6, 2015.

4.2.3 TEST PROCEDURE

For using ISN:

- a. The EUT is placed 0.4 meters from the conducting wall of the shielded room and connected to ISN directly to reference ground plane.
- b. If voltage measurement is used, measure voltage at the measurement port of the ISN, correct the reading by adding the ISN voltage division factor, and compare to the voltage limit.
- c. If current measurement is used, measure current with the current probe and compare to the current limit.
- d. It is not necessary to apply the voltage and the current limit if the ISN is used. A 50Ω load has to be connected to the measurement port of the ISN during the current measurement.
- e. The disturbance levels and the frequencies of at least six highest disturbances are recorded from be measured each telecommunication port, which comprises the EUT.

For using a 150 W load to the outside surface of the shield cable:

- a. Break the insulation and connect a 150Ω resistor from the outside surface of the shield cable to ground, and apply a ferrite tube or clamp between 150Ω connection and AE.
- b. The EUT is placed 0.4 meters from the conducting wall of the shielded room and connected to AE with the shield cable.
- c. Measure current with a current probe and compare to the current limit. The common mode impedance towards the right of the 150Ω resistor.
- d. The disturbance levels and the frequencies of at least six highest disturbances are recorded from be measured each telecommunication port, which comprises the EUT.

For using a combination of current probe and capacitive voltage probe:

- a. The EUT is placed 0.4 meters from the conducting wall of the shielded room and connected to AE with a cable. The cable contains more than four balanced pairs or to unbalanced cable.
- b. Measure current with a current probe and compare to the current limit.
- c. Measure voltage with a capacitive probe and adjust the measured voltage as follows:
 - current margin ≤ 6 dB – subtract the actual current margin from measured voltage;
 - current margin > 6 dB – subtract 6 dB from measured voltage.Compare adjusted voltage with the applicable voltage limit.
- d. Both the measured current and the adjusted voltage shall be below the applicable current and voltage limits.
- e. The disturbance levels and the frequencies of at least six highest disturbances are recorded from be measured each telecommunication port, which comprises the EUT.

4.2.4 DEVIATION FROM TEST STANDARD

No deviation

4.2.5 TEST SETUP

For using ISN:

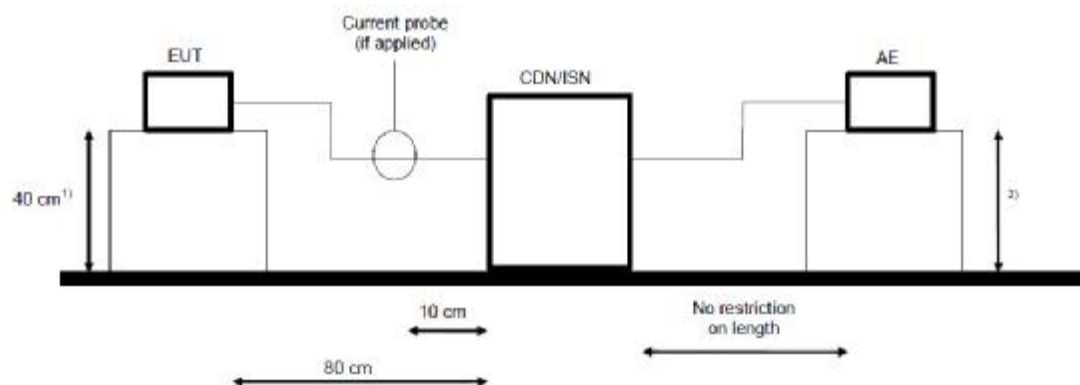

AE = Associated equipment
 EUT = Equipment under test

- 1) Distance to the reference groundplane (vertical or horizontal).
 2) Distance to the reference groundplane is not critical.

For using a 150 W load to the outside surface of the shield cable:

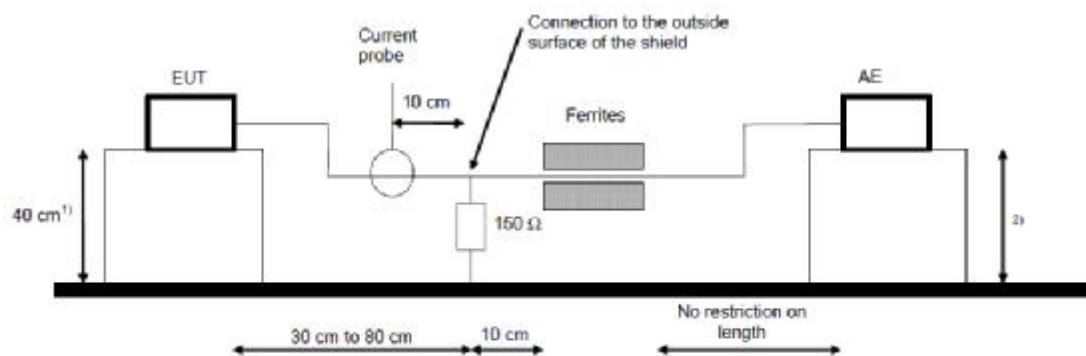

AE = Associated equipment
 EUT = Equipment under test

- 1) Distance to the reference groundplane (vertical or horizontal).
 2) Distance to the reference groundplane is not critical.

For using a combination of current probe and capacitive voltage probe:

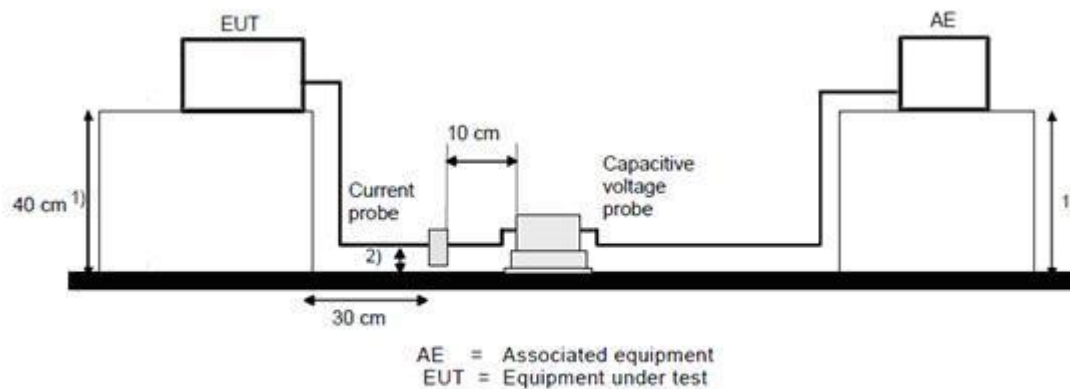

- 1) Distance to the reference groundplane (vertical or horizontal)
- 2) Distance 4 ± 1 cm from the reference groundplane.

For the actual test configuration, please refer to the related item – Photographs of the Test Configuration.

4.2.6 EUT OPERATING CONDITIONS

- a. Connected NB with EUT.
- b. Set EUT under online mode or green mode or battery mode continuously.
- c. Turned on the power of all equipment.
- d. Notebook ran a test program to enable all functions.
- e. EUT and NB run “TfGen.exe” + “ping” (286KB, 10% of transmission rate 10/100Mbps) then sent/ received messages to/from Wireless Broadband Router (kept in a remote area) via an UTP LAN cable (10m).
- f. Notebook read and wrote messages from HDD and ext.HDD.
- g. Notebook sent “H” messages to panel and then panel displayed “H” patterns on its screen.
- h. Notebook run “short to ulSim-TreeView.BAT” via RS-232.
- i. Notebook keeps watch on Notebook’s device manager “APC UPS” via USB.
- j. Universal’s sensor keep watch on environment temperature.
- k. Notebook sent messages to printer, and then printer printed it out.
- l. After test check EPO function.
- m. Steps e-l were repeated.

4.2.7 TEST RESULTS (1)

Frequency Range	150kHz ~ 30MHz	Detector Function & Bandwidth	Quasi-Peak (QP) / Average (AV), 9kHz
Input Power	230Vac, 50Hz	Environmental Conditions	24°C, 66%RH
Tested by	Jary Huang		
Test Mode	Mode 1 - RJ45 TELECOM PORT 10Mbps		

No	Frequency (MHz)	Correction Factor (dB)	Reading Value (dBuV)		Emission Level (dBuV)		Limit (dBuV)		Margin (dB)	
			Q.P.	AV.	Q.P.	AV.	Q.P.	AV.	Q.P.	AV.
1	0.91417	9.46	38.97	36.18	48.43	45.64	87.00	74.00	-38.57	-28.36
2	4.41016	9.39	42.52	39.63	51.91	49.02	87.00	74.00	-35.09	-24.98
3	8.91406	9.47	43.22	37.94	52.69	47.41	87.00	74.00	-34.31	-26.59
4	10.00000	9.49	38.14	32.21	47.63	41.70	87.00	74.00	-39.37	-32.30
5	13.23175	9.63	59.02	57.04	68.65	66.67	87.00	74.00	-18.35	-7.33
6	23.12763	10.15	51.10	48.48	61.25	58.63	87.00	74.00	-25.75	-15.37

Remarks:

1. Q.P. and AV. are abbreviations of quasi-peak and average individually.
2. The emission levels of other frequencies were very low against the limit.
3. Margin value = Emission level – Limit value
4. Correction factor = Insertion loss + Cable loss
5. Emission Level = Correction Factor + Reading Value

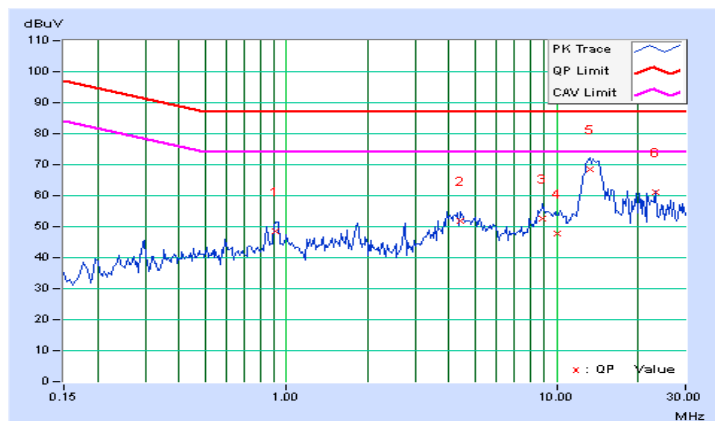



Frequency Range	150kHz ~ 30MHz	Detector Function & Bandwidth	Quasi-Peak (QP) / Average (AV), 9kHz
Input Power	230Vac, 50Hz	Environmental Conditions	24°C, 66%RH
Tested by	Jary Huang		
Test Mode	Mode 1 - RJ45 TELECOM PORT 100Mbps		

No	Frequency (MHz)	Correction Factor (dB)	Reading Value (dBuV)		Emission Level (dBuV)		Limit (dBuV)		Margin (dB)	
			Q.P.	AV.	Q.P.	AV.	Q.P.	AV.	Q.P.	AV.
1	0.93125	9.46	36.36	28.43	45.82	37.89	87.00	74.00	-41.18	-36.11
2	1.82785	9.40	39.57	35.29	48.97	44.69	87.00	74.00	-38.03	-29.31
3	4.41016	9.39	42.18	39.28	51.57	48.67	87.00	74.00	-35.43	-25.33
4	8.85156	9.47	43.61	38.28	53.08	47.75	87.00	74.00	-33.92	-26.25
5	13.35156	9.64	59.46	57.45	69.10	67.09	87.00	74.00	-17.90	-6.91
6	23.12840	10.15	50.90	48.01	61.05	58.16	87.00	74.00	-25.95	-15.84

Remarks:

1. Q.P. and AV. are abbreviations of quasi-peak and average individually.
2. The emission levels of other frequencies were very low against the limit.
3. Margin value = Emission level – Limit value
4. Correction factor = Insertion loss + Cable loss
5. Emission Level = Correction Factor + Reading Value

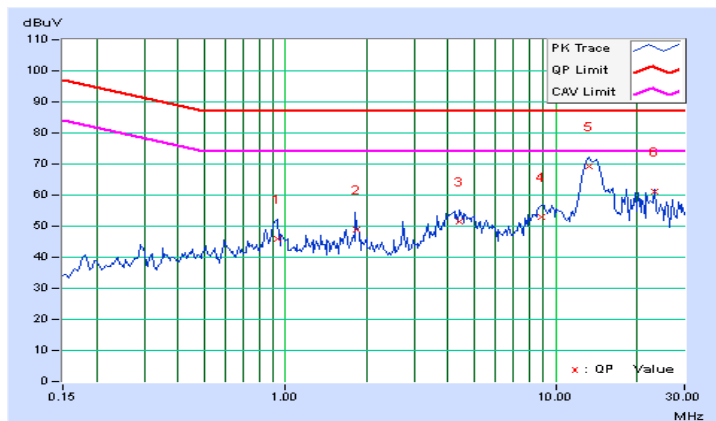

4.2.8 TEST RESULTS (2)

Frequency Range	150kHz ~ 30MHz	Detector Function & Bandwidth	Quasi-Peak (QP) / Average (AV), 9kHz
Input Power	208Vac, 50Hz	Environmental Conditions	24°C, 66%RH
Tested by	Jary Huang		
Test Mode	Mode 2 - RJ45 TELECOM PORT 10Mbps		

No	Frequency (MHz)	Correction Factor (dB)	Reading Value (dBuV)		Emission Level (dBuV)		Limit (dBuV)		Margin (dB)	
			Q.P.	AV.	Q.P.	AV.	Q.P.	AV.	Q.P.	AV.
1	0.88828	9.47	33.46	27.91	42.93	37.38	87.00	74.00	-44.07	-36.62
2	1.82031	9.40	40.11	32.85	49.51	42.25	87.00	74.00	-37.49	-31.75
3	4.31250	9.39	43.38	41.63	52.77	51.02	87.00	74.00	-34.23	-22.98
4	9.03125	9.47	44.69	39.56	54.16	49.03	87.00	74.00	-32.84	-24.97
5	10.00000	9.49	37.96	32.63	47.45	42.12	87.00	74.00	-39.55	-31.88
6	13.32159	9.64	58.11	56.22	67.75	65.86	87.00	74.00	-19.25	-8.14
7	23.12763	10.15	51.28	48.66	61.43	58.81	87.00	74.00	-25.57	-15.19

Remarks:

1. Q.P. and AV. are abbreviations of quasi-peak and average individually.
2. The emission levels of other frequencies were very low against the limit.
3. Margin value = Emission level – Limit value
4. Correction factor = Insertion loss + Cable loss
5. Emission Level = Correction Factor + Reading Value

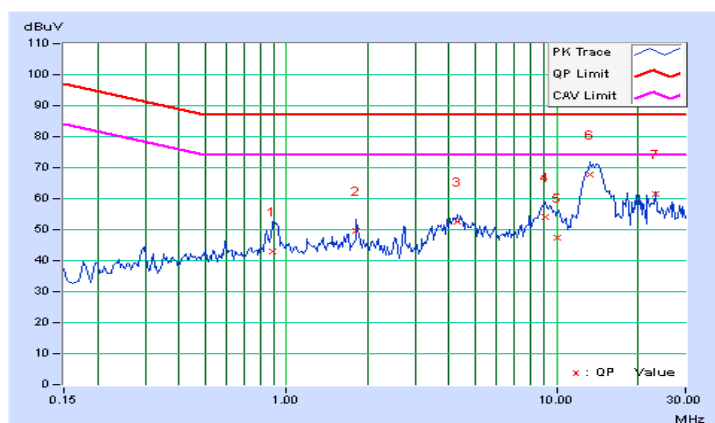



Frequency Range	150kHz ~ 30MHz	Detector Function & Bandwidth	Quasi-Peak (QP) / Average (AV), 9kHz
Input Power	208Vac, 50Hz	Environmental Conditions	24°C, 66%RH
Tested by	Jary Huang		
Test Mode	Mode 2 - RJ45 TELECOM PORT 100Mbps		

No	Frequency (MHz)	Correction Factor (dB)	Reading Value (dBuV)		Emission Level (dBuV)		Limit (dBuV)		Margin (dB)	
			Q.P.	AV.	Q.P.	AV.	Q.P.	AV.	Q.P.	AV.
1	0.91290	9.46	38.33	35.62	47.79	45.08	87.00	74.00	-39.21	-28.92
2	1.83203	9.40	40.56	35.85	49.96	45.25	87.00	74.00	-37.04	-28.75
3	4.40625	9.39	42.58	40.49	51.97	49.88	87.00	74.00	-35.03	-24.12
4	9.15234	9.47	44.08	38.99	53.55	48.46	87.00	74.00	-33.45	-25.54
5	13.80078	9.66	58.81	57.93	68.47	67.59	87.00	74.00	-18.53	-6.41
6	23.12891	10.15	50.68	47.75	60.83	57.90	87.00	74.00	-26.17	-16.10

Remarks:

1. Q.P. and AV. are abbreviations of quasi-peak and average individually.
2. The emission levels of other frequencies were very low against the limit.
3. Margin value = Emission level – Limit value
4. Correction factor = Insertion loss + Cable loss
5. Emission Level = Correction Factor + Reading Value

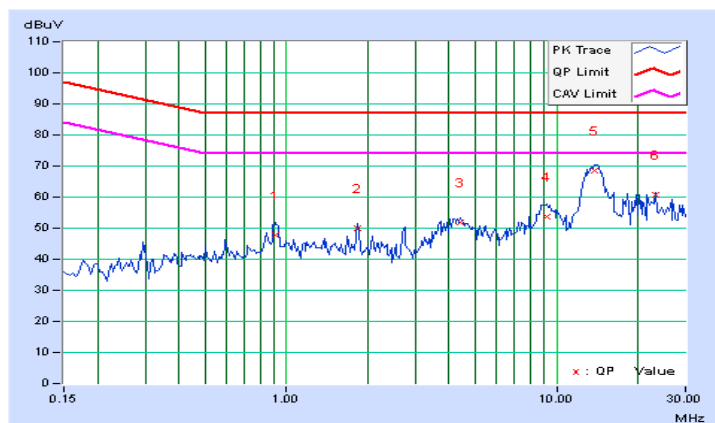

4.2.9 TEST RESULTS (3)

Frequency Range	150kHz ~ 30MHz	Detector Function & Bandwidth	Quasi-Peak (QP) / Average (AV), 9kHz
Input Power	230Vac, 50Hz	Environmental Conditions	24°C, 66%RH
Tested by	Jary Huang		
Test Mode	Mode 3 - RJ45 TELECOM PORT 10Mbps		

No	Frequency (MHz)	Correction Factor (dB)	Reading Value (dBuV)		Emission Level (dBuV)		Limit (dBuV)		Margin (dB)	
			Q.P.	AV.	Q.P.	AV.	Q.P.	AV.	Q.P.	AV.
1	0.84531	9.47	34.54	23.54	44.01	33.01	87.00	74.00	-42.99	-40.99
2	1.83203	9.40	40.29	35.47	49.69	44.87	87.00	74.00	-37.31	-29.13
3	4.41016	9.39	42.48	39.10	51.87	48.49	87.00	74.00	-35.13	-25.51
4	10.00000	9.49	37.75	32.35	47.24	41.84	87.00	74.00	-39.76	-32.16
5	13.86192	9.66	59.59	58.63	69.25	68.29	87.00	74.00	-17.75	-5.71
6	23.12741	10.15	51.08	48.48	61.23	58.63	87.00	74.00	-25.77	-15.37

Remarks:

1. Q.P. and AV. are abbreviations of quasi-peak and average individually.
2. The emission levels of other frequencies were very low against the limit.
3. Margin value = Emission level – Limit value
4. Correction factor = Insertion loss + Cable loss
5. Emission Level = Correction Factor + Reading Value

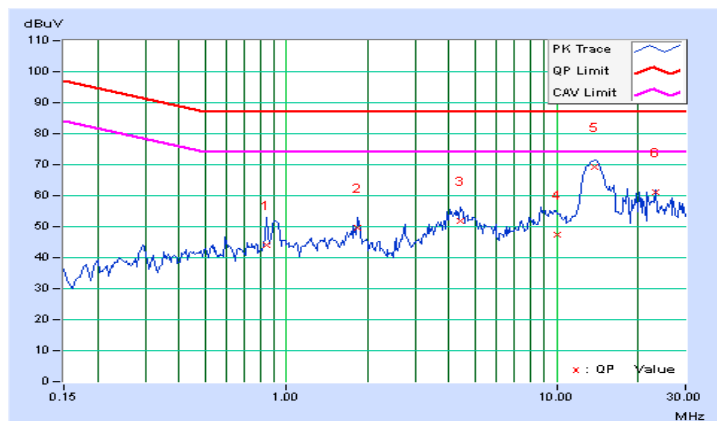



Frequency Range	150kHz ~ 30MHz	Detector Function & Bandwidth	Quasi-Peak (QP) / Average (AV), 9kHz
Input Power	230Vac, 50Hz	Environmental Conditions	24°C, 66%RH
Tested by	Jary Huang		
Test Mode	Mode 3 - RJ45 TELECOM PORT 100Mbps		

No	Frequency (MHz)	Correction Factor (dB)	Reading Value (dBUV)		Emission Level (dBUV)		Limit (dBUV)		Margin (dB)	
			Q.P.	AV.	Q.P.	AV.	Q.P.	AV.	Q.P.	AV.
1	0.29835	9.66	30.96	28.35	40.62	38.01	91.29	78.29	-50.67	-40.28
2	0.91571	9.46	39.11	35.90	48.57	45.36	87.00	74.00	-38.43	-28.64
3	1.82031	9.40	39.57	31.46	48.97	40.86	87.00	74.00	-38.03	-33.14
4	4.31378	9.39	43.44	41.51	52.83	50.90	87.00	74.00	-34.17	-23.10
5	13.98124	9.67	59.31	58.41	68.98	68.08	87.00	74.00	-18.02	-5.92
6	23.12763	10.15	51.02	48.33	61.17	58.48	87.00	74.00	-25.83	-15.52

Remarks:

1. Q.P. and AV. are abbreviations of quasi-peak and average individually.
2. The emission levels of other frequencies were very low against the limit.
3. Margin value = Emission level – Limit value
4. Correction factor = Insertion loss + Cable loss
5. Emission Level = Correction Factor + Reading Value

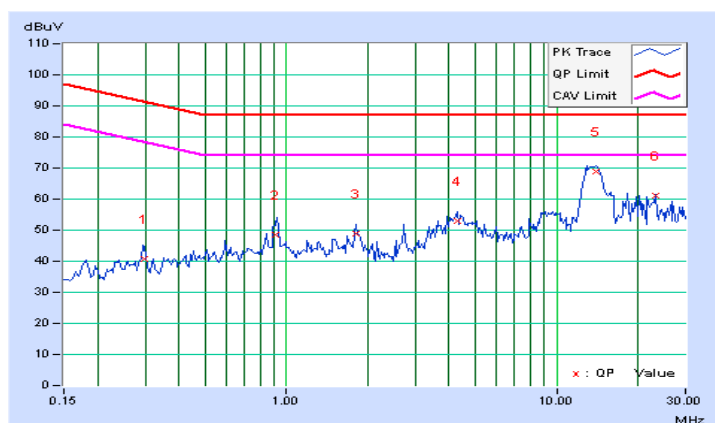

4.3 RADIATED EMISSION MEASUREMENT

4.3.1 LIMITS OF RADIATED EMISSION MEASUREMENT

FREQUENCY (MHz)	Quasi-peak limits (dBuV/m)	
	Category C1	Category C2
30 - 230	30	40
230 - 1000	37	47

NOTE: (1) Emission level (dBuV/m) = 20 log Emission level (uV/m).

(2) If the emission measurement at a 10 m cannot be made because of high ambient noise levels or for other reasons, measurement may be made at a closer distance 3m, as CISPR 22 (note 10.3.1)

4.3.2 TEST INSTRUMENTS

Description & Manufacturer	Model No.	Serial No.	Cal. Date	Cal. Due
Agilent Preamplifier	8447D	2944A11062	Feb. 27, 2015	Feb. 26, 2016
Agilent Preamplifier	8447D	2944A11064	Feb. 27, 2015	Feb. 26, 2016
Agilent Test Receiver	N9038A	MY50010158	Jul. 22, 2014	Jul. 21, 2015
Agilent Test Receiver	N9038A	MY51210114	Dec. 09, 2014	Dec. 08, 2015
Schwarzbeck Antenna	VULB9168	9168-316	Feb. 06, 2015	Feb. 05, 2016
Schwarzbeck Antenna	VULB9168	9168-317	Feb. 06, 2015	Feb. 05, 2016
Max Full. Turn Table & Tower	MF7802	MF7802121	NA	NA
Max Full. Tower	MF7802	MF780208105	NA	NA
Software	ADT_Radiated_V 8.7.07	NA	NA	NA
WOKEN RF cable	8D	CABLE-CH8-01.V	Dec. 17, 2014	Dec. 16, 2015
JYE BAO RF cable	8D	CABLE-CH8-02.H	Dec. 17, 2014	Dec. 16, 2015
JYE BAO RF cable	8D	CABLE-CH8-03.3M	Dec. 17, 2014	Dec. 16, 2015

Notes: 1. The calibration interval of the above test instruments is 12 months and the calibrations are traceable to NML/ROC and NIST/USA.

2. The test was performed in Chamber No. 8.
3. The Industry Canada Reference No. IC 7450E-8.
4. The VCCI Site Registration No. R-2946.
5. The FCC Site Registration No. 493821.
6. Tested Date: Apr. 30, 2015.

4.3.3 TEST PROCEDURE

- a. The EUT was placed on the top of a rotating table 0.8 meters above the ground at a 10-meter open area test site. The table was rotated 360 degrees to determine the position of the highest radiation.
- b. The EUT was set 10 meters away from the interference-receiving antenna, which was mounted on the top of a variable-height antenna tower.
- c. The height of antenna is varied from one meter to four meters above the ground to determine the maximum value of the field strength. Both horizontal and vertical polarizations of the antenna are set to make the measurement.
- d. For each suspected emission, the EUT was arranged to its worst case and then the antenna was tuned to heights from 1 meter to 4 meters and the rotatable table was turned from 0 degrees to 360 degrees to find the maximum reading.
- e. The test-receiver system was set to quasi-peak detect function and specified bandwidth with maximum hold mode when the test frequency is below 1 GHz.

NOTE: The resolution bandwidth of test receiver/spectrum analyzer is 120kHz for Quasi-peak detection (QP) at frequency below 1GHz.

4.3.4 DEVIATION FROM TEST STANDARD

No deviation

4.3.5 TEST SETUP

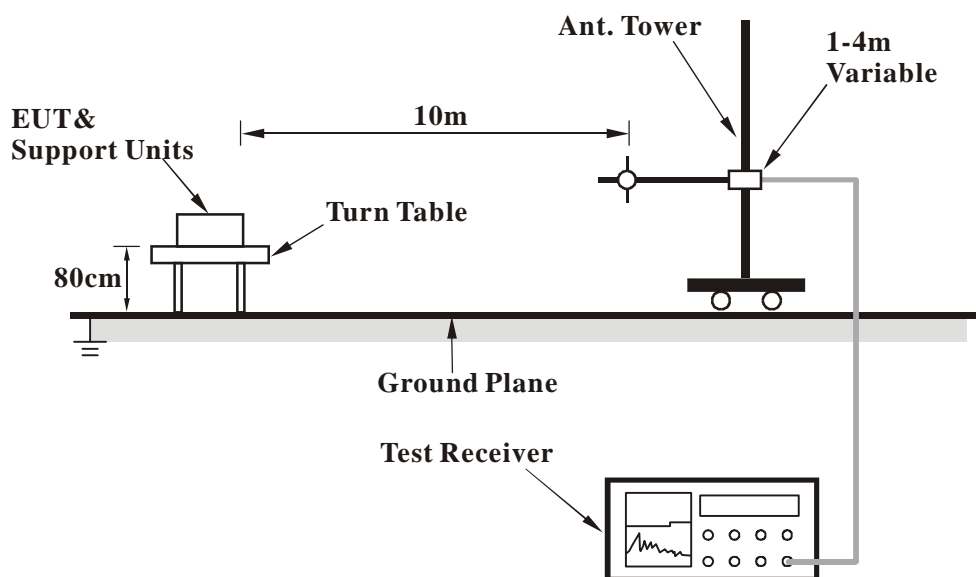

For the actual test configuration, please refer to the related item – Photographs of the Test Configuration.

4.3.6 EUT OPERATING CONDITIONS

Same as item 4.1.6.

4.3.7 TEST RESULTS (1)

Frequency Range	30MHz ~ 1GHz	Detector Function & Bandwidth	Quasi-Peak (QP), 120kHz
Input Power	230Vac, 50Hz	Environmental Conditions	24°C, 66%RH
Tested by	Jary Huang		
Test Mode	Mode 1A		

Antenna Polarity & Test Distance : Horizontal at 10 m								
No	Frequency (MHz)	Emission Level (dBuV/m)	Limit (dBuV/m)	Margin (dB)	Antenna Height (m)	Table Angle (Degree)	Raw Value (dBuV)	Correction Factor (dB/m)
1	67.10	33.53 QP	40.00	-6.47	3.42 H	315	47.82	-14.29
2	205.57	31.00 QP	40.00	-9.00	2.69 H	129	45.39	-14.39
3	300.00	41.22 QP	47.00	-5.78	3.13 H	224	50.95	-9.73
4	400.00	42.12 QP	47.00	-4.88	2.19 H	84	49.53	-7.41
5	662.54	37.66 QP	47.00	-9.34	1.88 H	194	39.34	-1.68
6	997.28	38.72 QP	47.00	-8.28	1.20 H	86	35.28	3.44

Remarks:

1. Emission Level(dBuV/m) = Raw Value(dBuV) + Correction Factor(dB/m)
2. Correction Factor(dB/m) = Antenna Factor (dB/m) + Cable Factor (dB) – Pre-Amplifier Factor (dB)
3. The other emission levels were very low against the limit.
4. Margin value = Emission level – Limit value

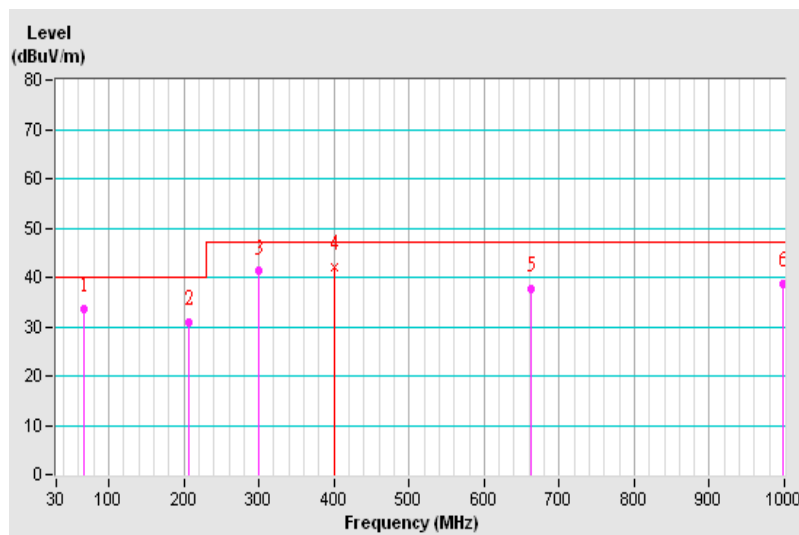



Frequency Range	30MHz ~ 1GHz	Detector Function & Bandwidth	Quasi-Peak (QP), 120kHz
Input Power	230Vac, 50Hz	Environmental Conditions	24°C, 66%RH
Tested by	Jary Huang		
Test Mode	Mode 1A		

Antenna Polarity & Test Distance : Vertical at 10 m

No	Frequency (MHz)	Emission Level (dBuV/m)	Limit (dBuV/m)	Margin (dB)	Antenna Height (m)	Table Angle (Degree)	Raw Value (dBuV)	Correction Factor (dB/m)
1	37.42	33.69 QP	40.00	-6.31	1.30 V	154	47.25	-13.56
2	67.76	34.61 QP	40.00	-5.39	1.02 V	225	48.50	-13.89
3	165.36	32.86 QP	40.00	-7.14	1.85 V	237	44.23	-11.37
4	300.00	40.86 QP	47.00	-6.14	2.63 V	111	50.29	-9.43
5	400.01	40.39 QP	47.00	-6.61	2.18 V	108	47.75	-7.36
6	662.49	35.76 QP	47.00	-11.24	3.36 V	60	37.85	-2.09
7	996.90	36.69 QP	47.00	-10.31	2.00 V	78	33.11	3.58

Remarks:

1. Emission Level(dBuV/m) = Raw Value(dBuV) + Correction Factor(dB/m)
2. Correction Factor(dB/m) = Antenna Factor (dB/m) + Cable Factor (dB) – Pre-Amplifier Factor (dB)
3. The other emission levels were very low against the limit.
4. Margin value = Emission level – Limit value

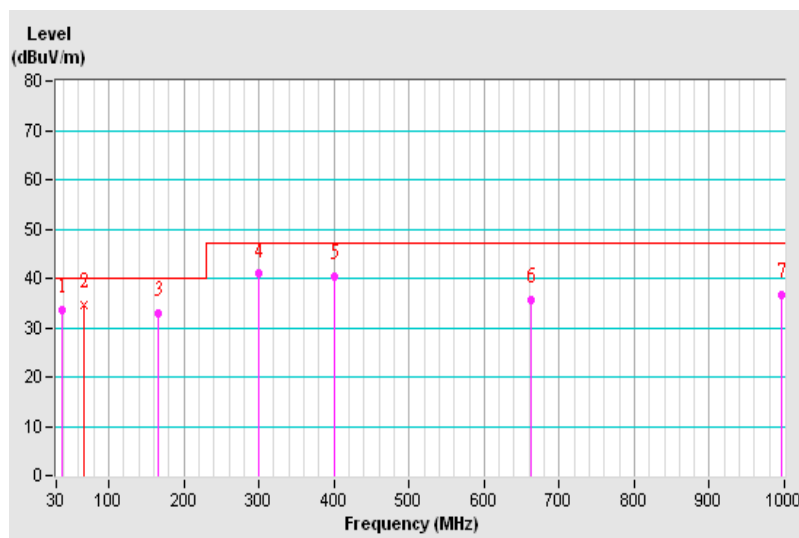

4.3.8 TEST RESULTS (2)

Frequency Range	30MHz ~ 1GHz	Detector Function & Bandwidth	Quasi-Peak (QP), 120kHz
Input Power	230Vac, 50Hz	Environmental Conditions	24°C, 66%RH
Tested by	Jary Huang		
Test Mode	Mode 1B		

Antenna Polarity & Test Distance : Horizontal at 10 m								
No	Frequency (MHz)	Emission Level (dBuV/m)	Limit (dBuV/m)	Margin (dB)	Antenna Height (m)	Table Angle (Degree)	Raw Value (dBuV)	Correction Factor (dB/m)
1	86.26	27.56 QP	40.00	-12.44	3.47 H	340	45.43	-17.87
2	137.38	27.97 QP	40.00	-12.03	3.23 H	96	40.63	-12.66
3	300.00	42.36 QP	47.00	-4.64	2.61 H	188	52.09	-9.73
4	400.01	41.54 QP	47.00	-5.46	2.40 H	115	48.95	-7.41
5	662.49	37.32 QP	47.00	-9.68	1.63 H	191	39.01	-1.69
6	825.01	35.30 QP	47.00	-11.70	3.81 H	195	34.16	1.14
7	996.90	40.46 QP	47.00	-6.54	1.43 H	79	37.03	3.43

Remarks:

1. Emission Level(dBuV/m) = Raw Value(dBuV) + Correction Factor(dB/m)
2. Correction Factor(dB/m) = Antenna Factor (dB/m) + Cable Factor (dB) – Pre-Amplifier Factor (dB)
3. The other emission levels were very low against the limit.
4. Margin value = Emission level – Limit value

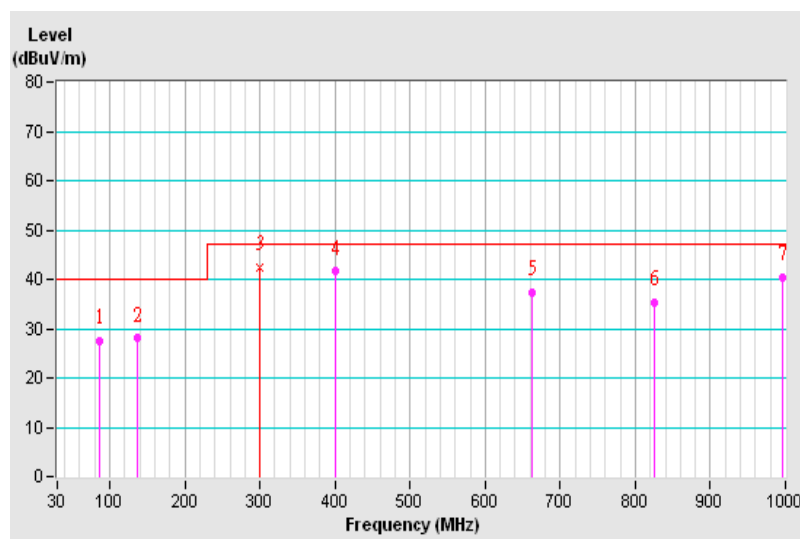



Frequency Range	30MHz ~ 1GHz	Detector Function & Bandwidth	Quasi-Peak (QP), 120kHz
Input Power	230Vac, 50Hz	Environmental Conditions	24°C, 66%RH
Tested by	Jary Huang		
Test Mode	Mode 1B		

Antenna Polarity & Test Distance : Vertical at 10 m

No	Frequency (MHz)	Emission Level (dBuV/m)	Limit (dBuV/m)	Margin (dB)	Antenna Height (m)	Table Angle (Degree)	Raw Value (dBuV)	Correction Factor (dB/m)
1	36.39	34.78 QP	40.00	-5.22	1.00 V	280	48.62	-13.84
2	76.80	31.71 QP	40.00	-8.29	1.35 V	186	47.51	-15.80
3	174.29	30.07 QP	40.00	-9.93	1.86 V	158	41.78	-11.71
4	275.02	41.14 QP	47.00	-5.86	2.31 V	290	51.46	-10.32
5	300.00	42.17 QP	47.00	-4.83	1.03 V	241	51.60	-9.43
6	400.01	40.22 QP	47.00	-6.78	3.51 V	129	47.58	-7.36
7	662.54	36.91 QP	47.00	-10.09	3.63 V	61	38.99	-2.08
8	997.28	36.41 QP	47.00	-10.59	2.13 V	47	32.83	3.58

Remarks:

1. Emission Level(dBuV/m) = Raw Value(dBuV) + Correction Factor(dB/m)
2. Correction Factor(dB/m) = Antenna Factor (dB/m) + Cable Factor (dB) - Pre-Amplifier Factor (dB)
3. The other emission levels were very low against the limit.
4. Margin value = Emission level - Limit value

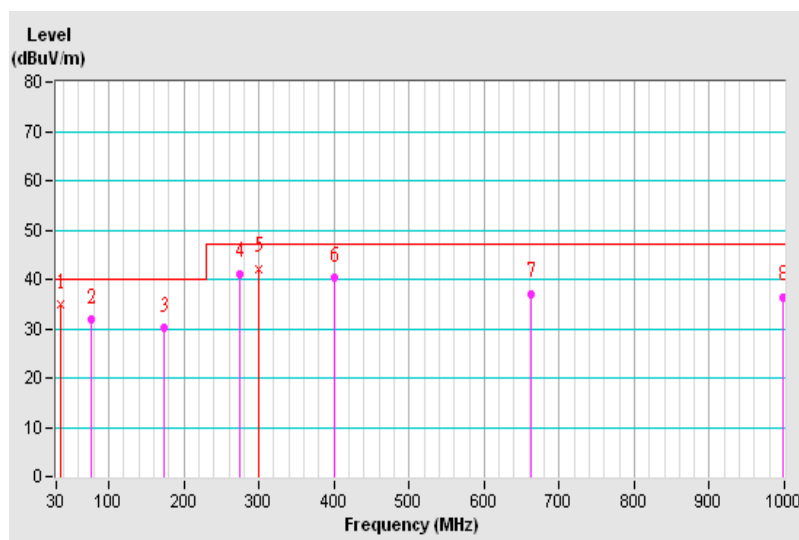

4.3.9 TEST RESULTS (3)

Frequency Range	30MHz ~ 1GHz	Detector Function & Bandwidth	Quasi-Peak (QP), 120kHz
Input Power	230Vac, 50Hz	Environmental Conditions	24°C, 66%RH
Tested by	Jary Huang		
Test Mode	Mode 1C		

Antenna Polarity & Test Distance : Horizontal at 10 m								
No	Frequency (MHz)	Emission Level (dBuV/m)	Limit (dBuV/m)	Margin (dB)	Antenna Height (m)	Table Angle (Degree)	Raw Value (dBuV)	Correction Factor (dB/m)
1	75.59	29.86 QP	40.00	-10.14	3.39 H	321	45.81	-15.95
2	275.02	38.04 QP	47.00	-8.96	2.61 H	317	48.72	-10.68
3	300.00	41.73 QP	47.00	-5.27	3.16 H	237	51.46	-9.73
4	350.00	38.27 QP	47.00	-8.73	2.17 H	220	46.98	-8.71
5	400.01	41.23 QP	47.00	-5.77	1.84 H	114	48.64	-7.41
6	450.01	34.41 QP	47.00	-12.59	2.03 H	358	40.38	-5.97
7	825.01	35.34 QP	47.00	-11.66	1.12 H	192	34.20	1.14

Remarks:

1. Emission Level(dBuV/m) = Raw Value(dBuV) + Correction Factor(dB/m)
2. Correction Factor(dB/m) = Antenna Factor (dB/m) + Cable Factor (dB) – Pre-Amplifier Factor (dB)
3. The other emission levels were very low against the limit.
4. Margin value = Emission level – Limit value

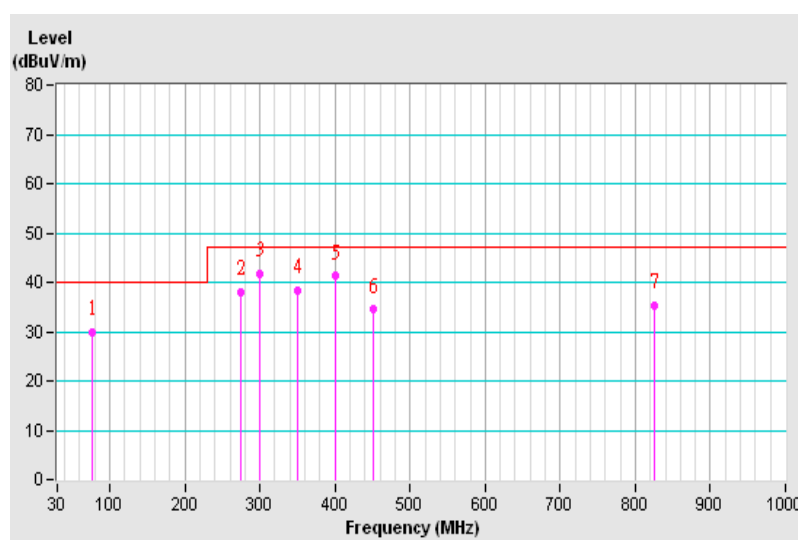



Frequency Range	30MHz ~ 1GHz	Detector Function & Bandwidth	Quasi-Peak (QP), 120kHz
Input Power	230Vac, 50Hz	Environmental Conditions	24°C, 66%RH
Tested by	Jary Huang		
Test Mode	Mode 1C		

Antenna Polarity & Test Distance : Vertical at 10 m

No	Frequency (MHz)	Emission Level (dBuV/m)	Limit (dBuV/m)	Margin (dB)	Antenna Height (m)	Table Angle (Degree)	Raw Value (dBuV)	Correction Factor (dB/m)
1	36.39	35.91 QP	40.00	-4.09	1.06 V	244	49.75	-13.84
2	76.75	33.94 QP	40.00	-6.06	1.32 V	236	49.72	-15.78
3	275.02	40.74 QP	47.00	-6.26	2.13 V	299	51.06	-10.32
4	300.00	40.96 QP	47.00	-6.04	1.82 V	235	50.39	-9.43
5	400.01	38.97 QP	47.00	-8.03	2.66 V	115	46.33	-7.36
6	750.03	33.56 QP	47.00	-13.44	4.00 V	279	33.84	-0.28
7	895.19	34.32 QP	47.00	-12.68	3.22 V	246	32.27	2.05

Remarks:

1. Emission Level(dBuV/m) = Raw Value(dBuV) + Correction Factor(dB/m)
2. Correction Factor(dB/m) = Antenna Factor (dB/m) + Cable Factor (dB) – Pre-Amplifier Factor (dB)
3. The other emission levels were very low against the limit.
4. Margin value = Emission level – Limit value

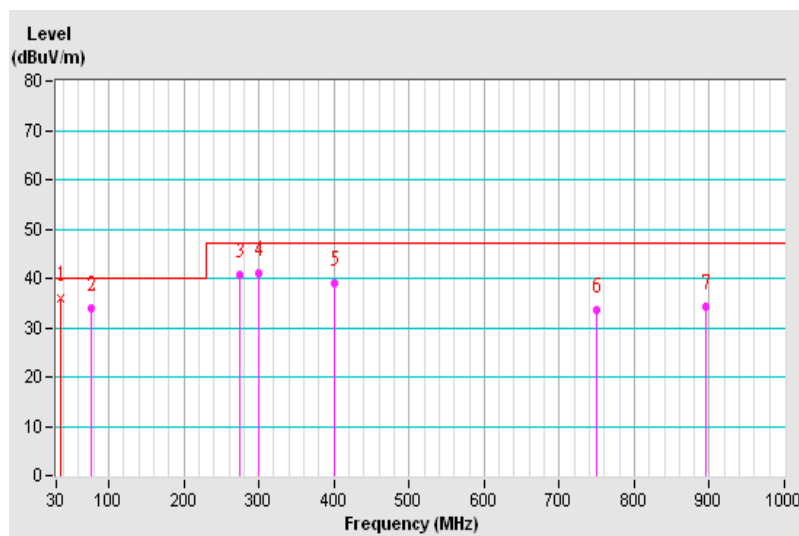

4.3.10 TEST RESULTS (4)

Frequency Range	30MHz ~ 1GHz	Detector Function & Bandwidth	Quasi-Peak (QP), 120kHz
Input Power	208Vac, 50Hz	Environmental Conditions	24°C, 66%RH
Tested by	Jary Huang		
Test Mode	Mode 2A		

Antenna Polarity & Test Distance : Horizontal at 10 m								
No	Frequency (MHz)	Emission Level (dBuV/m)	Limit (dBuV/m)	Margin (dB)	Antenna Height (m)	Table Angle (Degree)	Raw Value (dBuV)	Correction Factor (dB/m)
1	111.92	33.81 QP	40.00	-6.19	3.34 H	346	48.79	-14.98
2	203.58	32.36 QP	40.00	-7.64	2.63 H	230	46.76	-14.40
3	300.00	40.09 QP	47.00	-6.91	3.16 H	172	49.82	-9.73
4	400.01	40.24 QP	47.00	-6.76	2.26 H	130	47.65	-7.41
5	450.01	36.61 QP	47.00	-10.39	2.41 H	353	42.58	-5.97
6	825.01	34.78 QP	47.00	-12.22	1.85 H	302	33.64	1.14
7	927.49	35.10 QP	47.00	-11.90	1.00 H	202	32.05	3.05

Remarks:

1. Emission Level(dBuV/m) = Raw Value(dBuV) + Correction Factor(dB/m)
2. Correction Factor(dB/m) = Antenna Factor (dB/m) + Cable Factor (dB) – Pre-Amplifier Factor (dB)
3. The other emission levels were very low against the limit.
4. Margin value = Emission level – Limit value

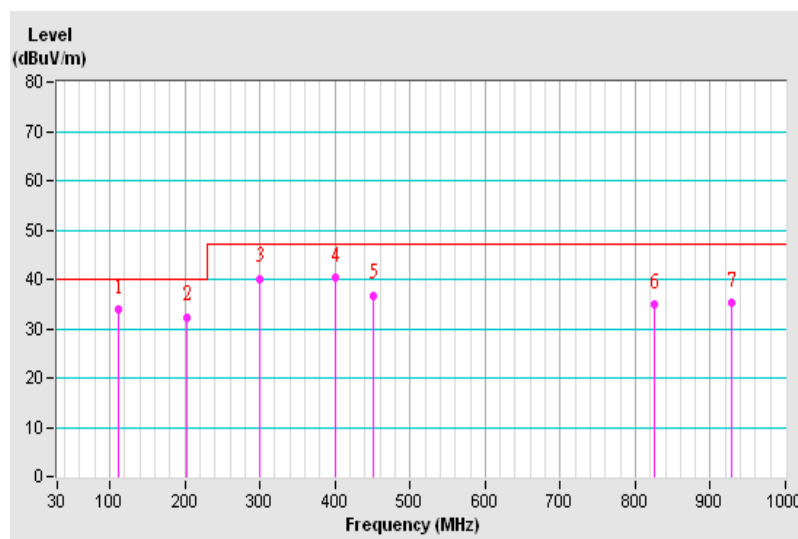



Frequency Range	30MHz ~ 1GHz	Detector Function & Bandwidth	Quasi-Peak (QP), 120kHz
Input Power	230Vac, 50Hz	Environmental Conditions	24°C, 66%RH
Tested by	Jary Huang		
Test Mode	Mode 2A		

Antenna Polarity & Test Distance : Vertical at 10 m

No	Frequency (MHz)	Emission Level (dBuV/m)	Limit (dBuV/m)	Margin (dB)	Antenna Height (m)	Table Angle (Degree)	Raw Value (dBuV)	Correction Factor (dB/m)
1	41.38	33.45 QP	40.00	-6.55	1.03 V	185	46.40	-12.95
2	82.14	33.76 QP	40.00	-6.24	1.00 V	330	50.67	-16.91
3	117.91	30.31 QP	40.00	-9.69	1.23 V	121	44.37	-14.06
4	300.00	38.31 QP	47.00	-8.69	2.41 V	302	47.74	-9.43
5	400.01	39.74 QP	47.00	-7.26	2.96 V	351	47.10	-7.36
6	662.54	38.76 QP	47.00	-8.24	3.42 V	312	40.84	-2.08
7	825.01	35.96 QP	47.00	-11.04	2.93 V	138	35.02	0.94

Remarks:

1. Emission Level(dBuV/m) = Raw Value(dBuV) + Correction Factor(dB/m)
2. Correction Factor(dB/m) = Antenna Factor (dB/m) + Cable Factor (dB) – Pre-Amplifier Factor (dB)
3. The other emission levels were very low against the limit.
4. Margin value = Emission level – Limit value

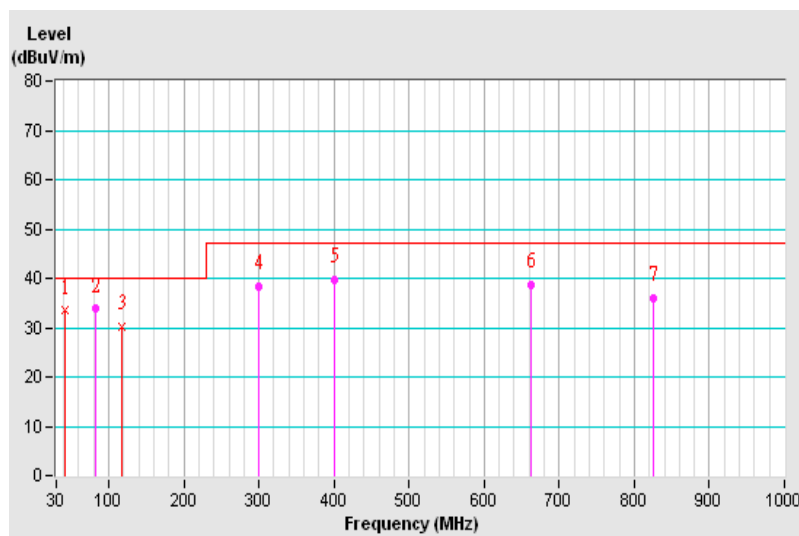

4.3.11 TEST RESULTS (5)

Frequency Range	30MHz ~ 1GHz	Detector Function & Bandwidth	Quasi-Peak (QP), 120kHz
Input Power	208Vac, 50Hz	Environmental Conditions	24°C, 66%RH
Tested by	Jary Huang		
Test Mode	Mode 2B		

Antenna Polarity & Test Distance : Horizontal at 10 m								
No	Frequency (MHz)	Emission Level (dBuV/m)	Limit (dBuV/m)	Margin (dB)	Antenna Height (m)	Table Angle (Degree)	Raw Value (dBuV)	Correction Factor (dB/m)
1	149.94	30.75 QP	40.00	-9.25	3.64 H	73	42.72	-11.97
2	265.03	34.98 QP	47.00	-12.02	1.68 H	266	46.28	-11.30
3	300.00	40.37 QP	47.00	-6.63	2.43 H	175	50.10	-9.73
4	400.01	40.82 QP	47.00	-6.18	1.60 H	134	48.23	-7.41
5	500.01	33.16 QP	47.00	-13.84	2.76 H	0	38.52	-5.36
6	825.01	34.31 QP	47.00	-12.69	1.21 H	304	33.17	1.14
7	927.54	35.52 QP	47.00	-11.48	3.75 H	232	32.47	3.05

Remarks:

1. Emission Level(dBuV/m) = Raw Value(dBuV) + Correction Factor(dB/m)
2. Correction Factor(dB/m) = Antenna Factor (dB/m) + Cable Factor (dB) – Pre-Amplifier Factor (dB)
3. The other emission levels were very low against the limit.
4. Margin value = Emission level – Limit value

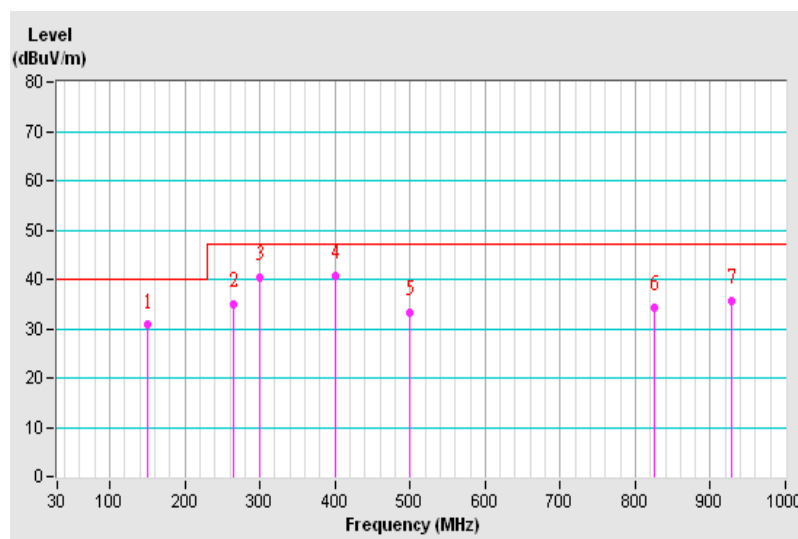

Frequency Range	30MHz ~ 1GHz	Detector Function & Bandwidth	Quasi-Peak (QP), 120kHz
Input Power	208Vac, 50Hz	Environmental Conditions	24°C, 66%RH
Tested by	Jary Huang		
Test Mode	Mode 2B		

Antenna Polarity & Test Distance : Vertical at 10 m

No	Frequency (MHz)	Emission Level (dBuV/m)	Limit (dBuV/m)	Margin (dB)	Antenna Height (m)	Table Angle (Degree)	Raw Value (dBuV)	Correction Factor (dB/m)
1	41.40	31.55 QP	40.00	-8.45	1.13 V	164	44.50	-12.95
2	122.64	33.62 QP	40.00	-6.38	1.68 V	104	47.40	-13.78
3	169.53	34.48 QP	40.00	-5.52	2.14 V	165	45.92	-11.44
4	300.00	39.41 QP	47.00	-7.59	3.21 V	5	48.84	-9.43
5	400.01	40.07 QP	47.00	-6.93	2.46 V	356	47.43	-7.36
6	662.54	39.54 QP	47.00	-7.46	3.72 V	299	41.62	-2.08
7	825.01	35.66 QP	47.00	-11.34	3.00 V	169	34.72	0.94

Remarks:

1. Emission Level(dBuV/m) = Raw Value(dBuV) + Correction Factor(dB/m)
2. Correction Factor(dB/m) = Antenna Factor (dB/m) + Cable Factor (dB) – Pre-Amplifier Factor (dB)
3. The other emission levels were very low against the limit.
4. Margin value = Emission level – Limit value

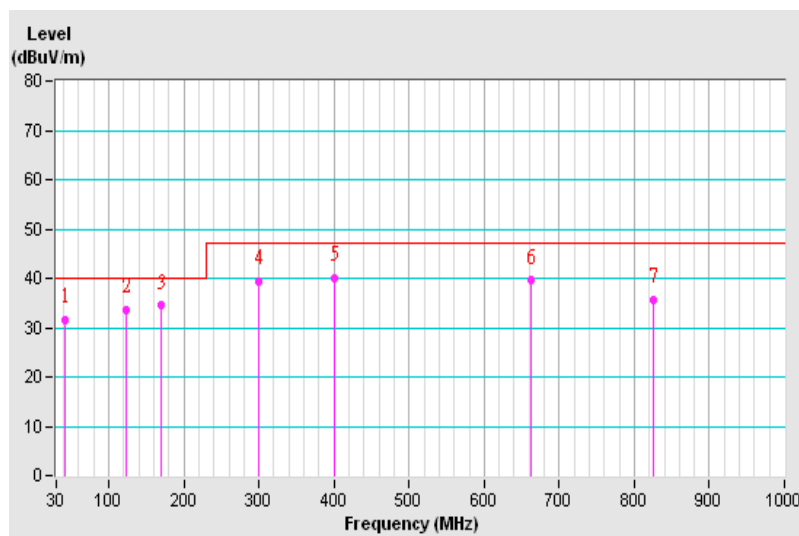

4.3.12 TEST RESULTS (6)

Frequency Range	30MHz ~ 1GHz	Detector Function & Bandwidth	Quasi-Peak (QP), 120kHz
Input Power	208Vac, 50Hz	Environmental Conditions	24°C, 66%RH
Tested by	Jary Huang		
Test Mode	Mode 2C		

Antenna Polarity & Test Distance : Horizontal at 10 m								
No	Frequency (MHz)	Emission Level (dBuV/m)	Limit (dBuV/m)	Margin (dB)	Antenna Height (m)	Table Angle (Degree)	Raw Value (dBuV)	Correction Factor (dB/m)
1	91.16	31.55 QP	40.00	-8.45	3.82 H	74	49.53	-17.98
2	300.00	40.76 QP	47.00	-6.24	3.23 H	170	50.49	-9.73
3	400.01	39.82 QP	47.00	-7.18	2.75 H	133	47.23	-7.41
4	450.01	35.82 QP	47.00	-11.18	2.32 H	355	41.79	-5.97
5	600.02	32.34 QP	47.00	-14.66	1.67 H	90	35.12	-2.78
6	825.01	34.08 QP	47.00	-12.92	1.29 H	300	32.94	1.14
7	927.54	35.36 QP	47.00	-11.64	2.53 H	271	32.31	3.05

Remarks:

1. Emission Level(dBuV/m) = Raw Value(dBuV) + Correction Factor(dB/m)
2. Correction Factor(dB/m) = Antenna Factor (dB/m) + Cable Factor (dB) – Pre-Amplifier Factor (dB)
3. The other emission levels were very low against the limit.
4. Margin value = Emission level – Limit value

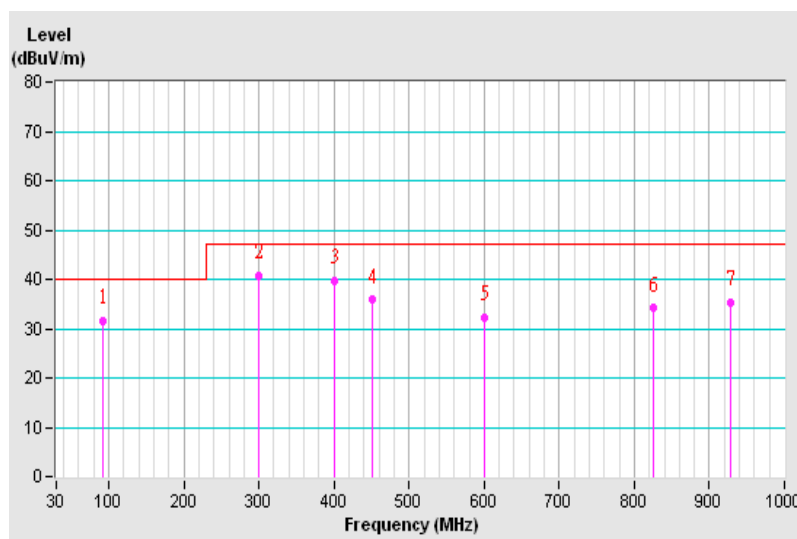



Frequency Range	30MHz ~ 1GHz	Detector Function & Bandwidth	Quasi-Peak (QP), 120kHz
Input Power	208Vac, 50Hz	Environmental Conditions	24°C, 66%RH
Tested by	Jary Huang		
Test Mode	Mode 2C		

Antenna Polarity & Test Distance : Vertical at 10 m

No	Frequency (MHz)	Emission Level (dBuV/m)	Limit (dBuV/m)	Margin (dB)	Antenna Height (m)	Table Angle (Degree)	Raw Value (dBuV)	Correction Factor (dB/m)
1	41.35	31.17 QP	40.00	-8.83	1.03 V	164	44.12	-12.95
2	123.94	33.78 QP	40.00	-6.22	1.62 V	101	47.39	-13.61
3	300.00	38.98 QP	47.00	-8.02	2.71 V	310	48.41	-9.43
4	400.01	39.98 QP	47.00	-7.02	2.52 V	2	47.34	-7.36
5	662.54	39.58 QP	47.00	-7.42	3.84 V	302	41.66	-2.08
6	825.01	36.48 QP	47.00	-10.52	3.13 V	138	35.54	0.94

Remarks:

1. Emission Level(dBuV/m) = Raw Value(dBuV) + Correction Factor(dB/m)
2. Correction Factor(dB/m) = Antenna Factor (dB/m) + Cable Factor (dB)
– Pre-Amplifier Factor (dB)
3. The other emission levels were very low against the limit.
4. Margin value = Emission level – Limit value

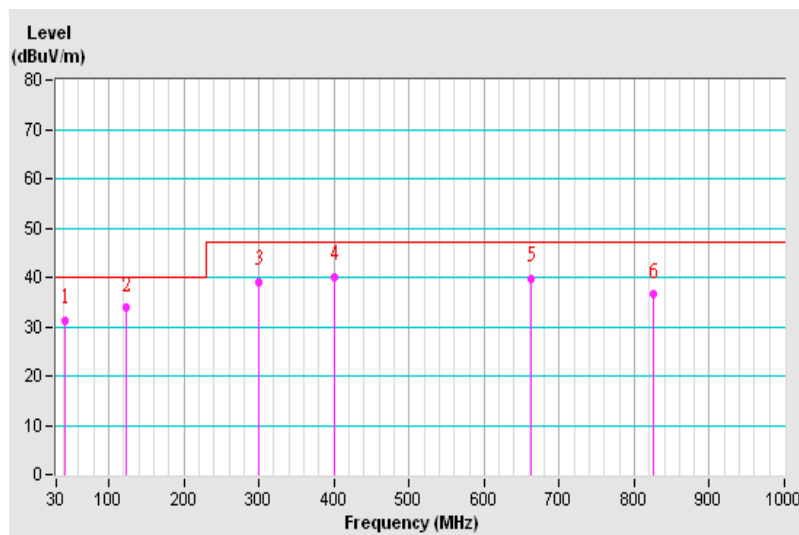

4.3.13 TEST RESULTS (7)

Frequency Range	30MHz ~ 1GHz	Detector Function & Bandwidth	Quasi-Peak (QP), 120kHz
Input Power	230Vac, 50Hz	Environmental Conditions	24°C, 66%RH
Tested by	Jary Huang		
Test Mode	Mode 3A		

Antenna Polarity & Test Distance : Horizontal at 10 m								
No	Frequency (MHz)	Emission Level (dBuV/m)	Limit (dBuV/m)	Margin (dB)	Antenna Height (m)	Table Angle (Degree)	Raw Value (dBuV)	Correction Factor (dB/m)
1	102.60	33.60 QP	40.00	-6.40	4.00 H	313	50.02	-16.42
2	250.00	38.41 QP	47.00	-8.59	3.00 H	155	50.39	-11.98
3	300.00	39.91 QP	47.00	-7.09	3.00 H	280	49.64	-9.73
4	400.01	36.80 QP	47.00	-10.20	2.00 H	59	44.21	-7.41
5	500.01	40.28 QP	47.00	-6.72	2.00 H	230	45.64	-5.36
6	662.54	40.80 QP	47.00	-6.20	1.00 H	115	42.48	-1.68
7	775.01	34.27 QP	47.00	-12.73	1.00 H	56	33.90	0.37

Remarks:

1. Emission Level(dBuV/m) = Raw Value(dBuV) + Correction Factor(dB/m)
2. Correction Factor(dB/m) = Antenna Factor (dB/m) + Cable Factor (dB) – Pre-Amplifier Factor (dB)
3. The other emission levels were very low against the limit.
4. Margin value = Emission level – Limit value

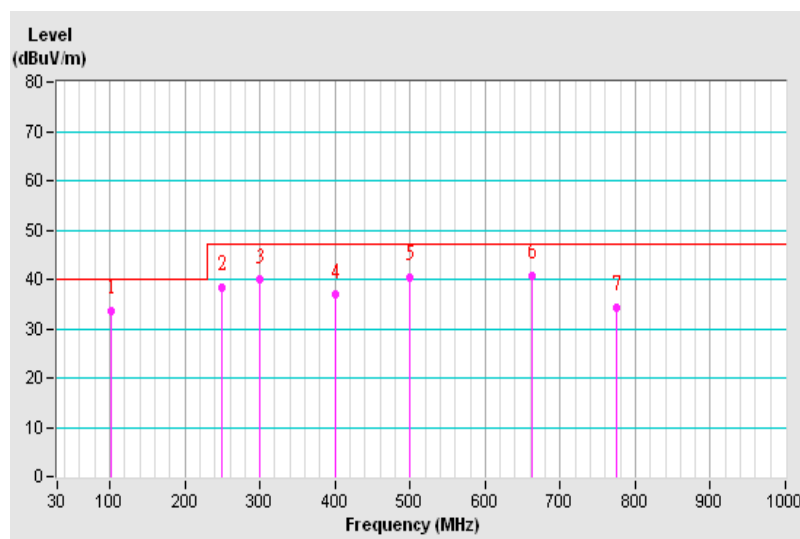



Frequency Range	30MHz ~ 1GHz	Detector Function & Bandwidth	Quasi-Peak (QP), 120kHz
Input Power	230Vac, 50Hz	Environmental Conditions	24°C, 66%RH
Tested by	Jary Huang		
Test Mode	Mode 3A		

Antenna Polarity & Test Distance : Vertical at 10 m

No	Frequency (MHz)	Emission Level (dBuV/m)	Limit (dBuV/m)	Margin (dB)	Antenna Height (m)	Table Angle (Degree)	Raw Value (dBuV)	Correction Factor (dB/m)
1	55.32	34.14 QP	40.00	-5.86	1.62 V	312	46.55	-12.41
2	69.76	32.83 QP	40.00	-7.17	1.02 V	270	46.63	-13.80
3	197.76	33.12 QP	40.00	-6.88	2.33 V	327	47.08	-13.96
4	300.00	40.86 QP	47.00	-6.14	1.08 V	100	50.29	-9.43
5	400.01	37.15 QP	47.00	-9.85	3.22 V	353	44.51	-7.36
6	500.01	36.12 QP	47.00	-10.88	1.92 V	194	41.03	-4.91
7	750.03	33.28 QP	47.00	-13.72	2.46 V	120	33.56	-0.28
8	875.02	34.58 QP	47.00	-12.42	3.39 V	302	32.99	1.59

Remarks:

1. Emission Level(dBuV/m) = Raw Value(dBuV) + Correction Factor(dB/m)
2. Correction Factor(dB/m) = Antenna Factor (dB/m) + Cable Factor (dB) – Pre-Amplifier Factor (dB)
3. The other emission levels were very low against the limit.
4. Margin value = Emission level – Limit value

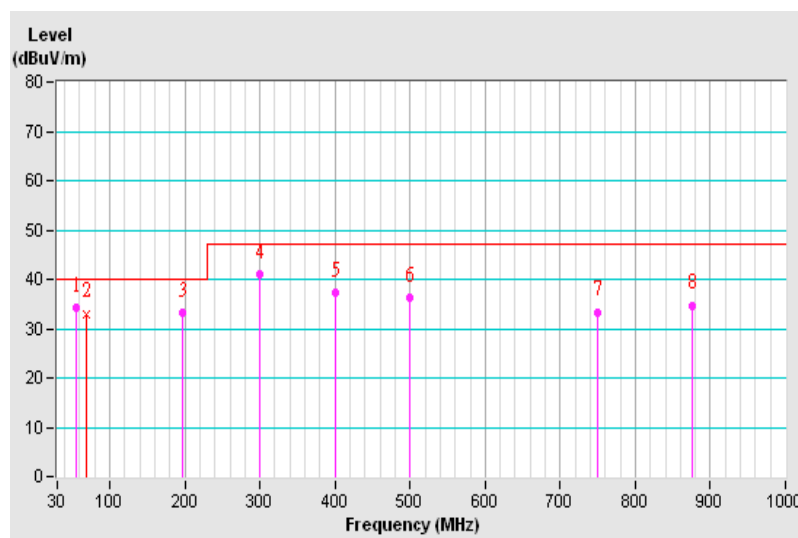

4.3.14 TEST RESULTS (8)

Frequency Range	30MHz ~ 1GHz	Detector Function & Bandwidth	Quasi-Peak (QP), 120kHz
Input Power	230Vac, 50Hz	Environmental Conditions	24°C, 66%RH
Tested by	Jary Huang		
Test Mode	Mode 3B		

Antenna Polarity & Test Distance : Horizontal at 10 m								
No	Frequency (MHz)	Emission Level (dBuV/m)	Limit (dBuV/m)	Margin (dB)	Antenna Height (m)	Table Angle (Degree)	Raw Value (dBuV)	Correction Factor (dB/m)
1	136.55	33.57 QP	40.00	-6.43	3.00 H	72	46.31	-12.74
2	250.00	38.61 QP	47.00	-8.39	4.00 H	162	50.59	-11.98
3	300.00	40.07 QP	47.00	-6.93	2.50 H	196	49.80	-9.73
4	400.01	36.24 QP	47.00	-10.76	2.50 H	68	43.65	-7.41
5	500.01	38.82 QP	47.00	-8.18	2.00 H	231	44.18	-5.36
6	662.51	39.75 QP	47.00	-7.25	1.44 H	147	41.43	-1.68
7	775.01	35.38 QP	47.00	-11.62	1.50 H	56	35.01	0.37
8	925.02	35.50 QP	47.00	-11.50	1.50 H	93	32.45	3.05

Remarks:

1. Emission Level(dBuV/m) = Raw Value(dBuV) + Correction Factor(dB/m)
2. Correction Factor(dB/m) = Antenna Factor (dB/m) + Cable Factor (dB) – Pre-Amplifier Factor (dB)
3. The other emission levels were very low against the limit.
4. Margin value = Emission level – Limit value

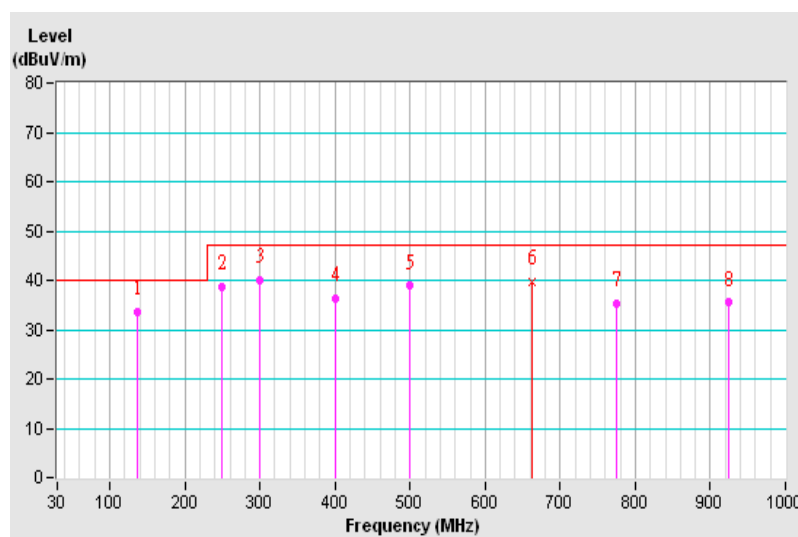

Frequency Range	30MHz ~ 1GHz	Detector Function & Bandwidth	Quasi-Peak (QP), 120kHz
Input Power	230Vac, 50Hz	Environmental Conditions	24°C, 66%RH
Tested by	Jary Huang		
Test Mode	Mode 3B		

Antenna Polarity & Test Distance : Vertical at 10 m

No	Frequency (MHz)	Emission Level (dBuV/m)	Limit (dBuV/m)	Margin (dB)	Antenna Height (m)	Table Angle (Degree)	Raw Value (dBuV)	Correction Factor (dB/m)
1	50.35	32.60 QP	40.00	-7.40	1.00 V	59	44.91	-12.31
2	125.45	33.04 QP	40.00	-6.96	2.50 V	4	46.67	-13.63
3	190.73	33.46 QP	40.00	-6.54	1.00 V	314	47.14	-13.68
4	300.00	40.91 QP	47.00	-6.09	1.00 V	283	50.34	-9.43
5	400.01	38.48 QP	47.00	-8.52	1.00 V	328	45.84	-7.36
6	662.54	37.11 QP	47.00	-9.89	2.00 V	113	39.19	-2.08
7	775.01	37.30 QP	47.00	-9.70	3.00 V	310	37.19	0.11

Remarks:

1. Emission Level(dBuV/m) = Raw Value(dBuV) + Correction Factor(dB/m)
2. Correction Factor(dB/m) = Antenna Factor (dB/m) + Cable Factor (dB) – Pre-Amplifier Factor (dB)
3. The other emission levels were very low against the limit.
4. Margin value = Emission level – Limit value

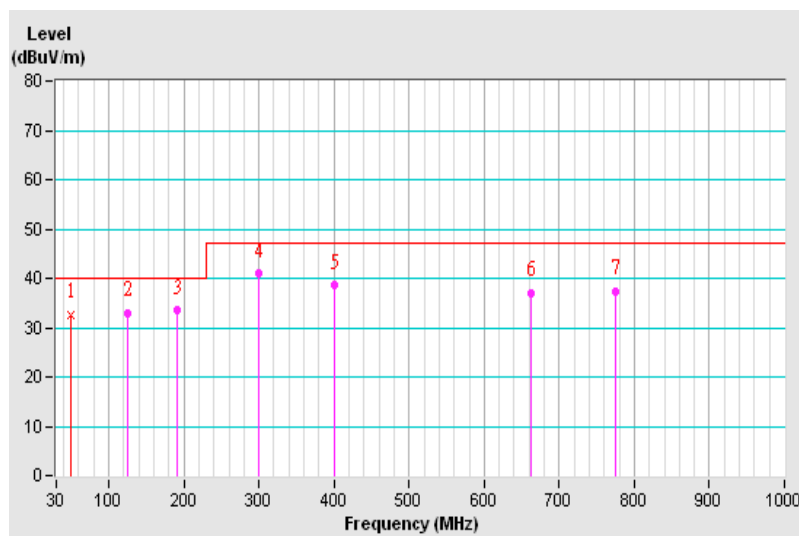

4.3.15 TEST RESULTS (9)

Frequency Range	30MHz ~ 1GHz	Detector Function & Bandwidth	Quasi-Peak (QP), 120kHz
Input Power	230Vac, 50Hz	Environmental Conditions	24°C, 66%RH
Tested by	Jary Huang		
Test Mode	Mode 3C		

Antenna Polarity & Test Distance : Horizontal at 10 m								
No	Frequency (MHz)	Emission Level (dBuV/m)	Limit (dBuV/m)	Margin (dB)	Antenna Height (m)	Table Angle (Degree)	Raw Value (dBuV)	Correction Factor (dB/m)
1	101.97	27.44 QP	40.00	-12.56	3.38 H	356	44.04	-16.60
2	250.00	38.40 QP	47.00	-8.60	3.68 H	199	50.38	-11.98
3	300.00	39.90 QP	47.00	-7.10	2.49 H	323	49.63	-9.73
4	400.01	36.50 QP	47.00	-10.50	2.16 H	107	43.91	-7.41
5	500.01	39.09 QP	47.00	-7.91	1.84 H	271	44.45	-5.36
6	775.01	34.98 QP	47.00	-12.02	2.67 H	105	34.61	0.37
7	925.02	34.33 QP	47.00	-12.67	1.32 H	129	31.28	3.05

Remarks:

1. Emission Level(dBuV/m) = Raw Value(dBuV) + Correction Factor(dB/m)
2. Correction Factor(dB/m) = Antenna Factor (dB/m) + Cable Factor (dB) – Pre-Amplifier Factor (dB)
3. The other emission levels were very low against the limit.
4. Margin value = Emission level – Limit value

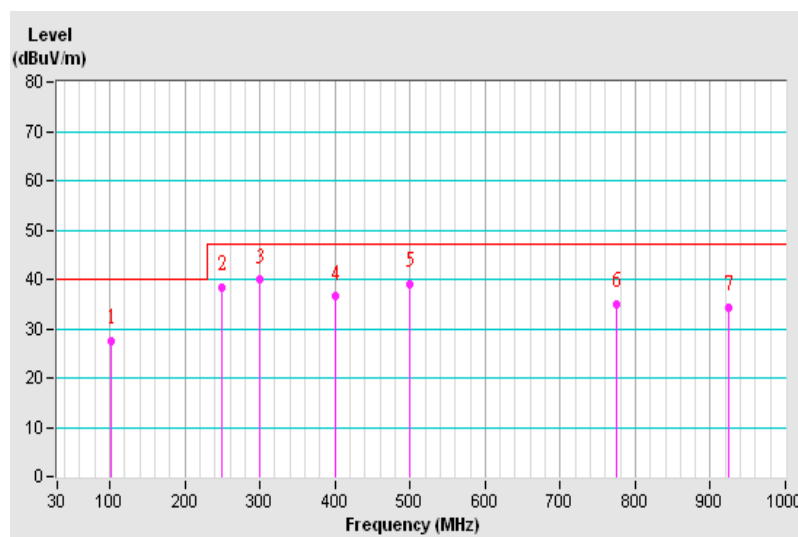

Frequency Range	30MHz ~ 1GHz	Detector Function & Bandwidth	Quasi-Peak (QP), 120kHz
Input Power	230Vac, 50Hz	Environmental Conditions	24°C, 66%RH
Tested by	Jary Huang		
Test Mode	Mode 3C		

Antenna Polarity & Test Distance : Vertical at 10 m

No	Frequency (MHz)	Emission Level (dBuV/m)	Limit (dBuV/m)	Margin (dB)	Antenna Height (m)	Table Angle (Degree)	Raw Value (dBuV)	Correction Factor (dB/m)
1	50.34	31.99 QP	40.00	-8.01	1.03 V	73	44.30	-12.31
2	64.80	32.03 QP	40.00	-7.97	1.26 V	189	45.27	-13.24
3	100.03	28.96 QP	40.00	-11.04	1.43 V	332	45.20	-16.24
4	300.00	40.65 QP	47.00	-6.35	2.67 V	256	50.08	-9.43
5	350.00	39.29 QP	47.00	-7.71	3.11 V	284	47.96	-8.67
6	500.01	35.58 QP	47.00	-11.42	2.47 V	123	40.49	-4.91
7	662.54	36.82 QP	47.00	-10.18	2.36 V	78	38.90	-2.08
8	775.01	36.41 QP	47.00	-10.59	3.00 V	306	36.30	0.11

Remarks:

1. Emission Level(dBuV/m) = Raw Value(dBuV) + Correction Factor(dB/m)
2. Correction Factor(dB/m) = Antenna Factor (dB/m) + Cable Factor (dB) – Pre-Amplifier Factor (dB)
3. The other emission levels were very low against the limit.
4. Margin value = Emission level – Limit value

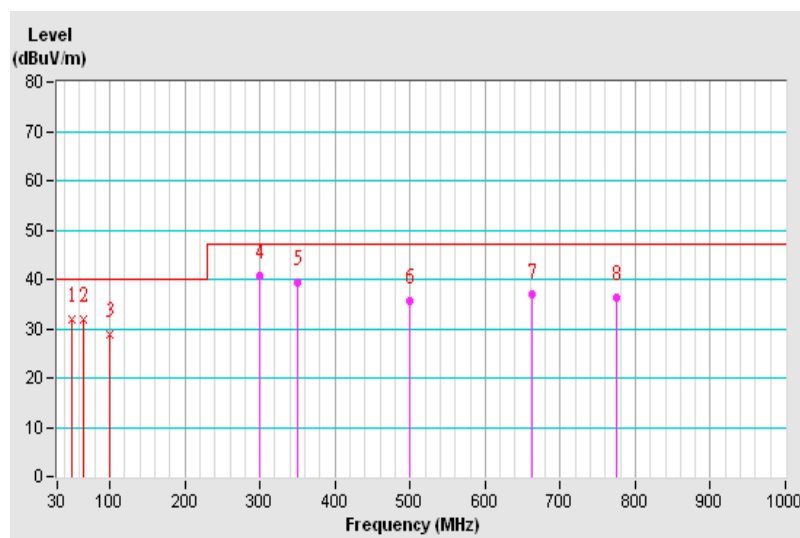

4.4 HARMONICS CURRENT MEASUREMENT

4.4.1 LIMITS OF HARMONICS CURRENT MEASUREMENT

TEST STANDARD: IEC 61000-3-2

Limits for Class A equipment		Limits for Class D equipment		
Harmonics Order n	Max. permissible harmonics current A	Harmonics Order n	Max. permissible harmonics current per watt mAW	Max. permissible harmonics current A
Odd harmonics		Odd Harmonics only		
3	2.30	3	3.4	2.30
5	1.14	5	1.9	1.14
7	0.77	7	1.0	0.77
9	0.40	9	0.5	0.40
11	0.33	11	0.35	0.33
13	0.21	13	0.30	0.21
15<=n<=39	0.15x15/n	15<=n<=39	3.85/n	0.15x15/n
Even harmonics				
2	1.08			
4	0.43			
6	0.30			
8<=n<=40	0.23x8/n			

- NOTE:** 1. Class A and Class D are classified according to section 5 of IEC 61000-3-2.
2. According to section 7 of IEC 61000-3-2, the above limits for all equipment except for lighting equipment are for all applications having an active input power > 75 W and no limits apply for equipment with an active input power up to and including 75 W.

4.4.2 TEST INSTRUMENTS

Description & Manufacturer	Model No.	Serial No.	Cal. Date	Cal. Due
EMC PARTNER EMC Emission Tester	HAR1000-1P	084	Apr. 24, 2015	Apr. 23, 2016
Software	HARCS	NA	NA	NA

- Notes: 1. The calibration interval of the above test instruments is 12 months and the calibrations are traceable to NML/ROC and NIST/USA.
2. The test was performed in EMS Room No. 2.
3. According to IEC 61000-4-7: 2002, the time window shall be synchronized with each group of 10 or 12 cycles (200 ms) for power frequency of 50 or 60Hz.
4. Tested Date: May 8, 2015.

4.4.3 TEST PROCEDURE

- a. The EUT was placed on the top of a wooden table 0.8 meters above the ground and operated to produce the maximum harmonic components under normal operating conditions for each successive harmonic component in turn.
- b. The correspondent test program of test instrument to measure the current harmonics emanated from EUT is chosen. The measure time shall be not less than the time necessary for the EUT to be exercised.

4.4.4 DEVIATION FROM TEST STANDARD

No deviation

4.4.5 TEST SETUP

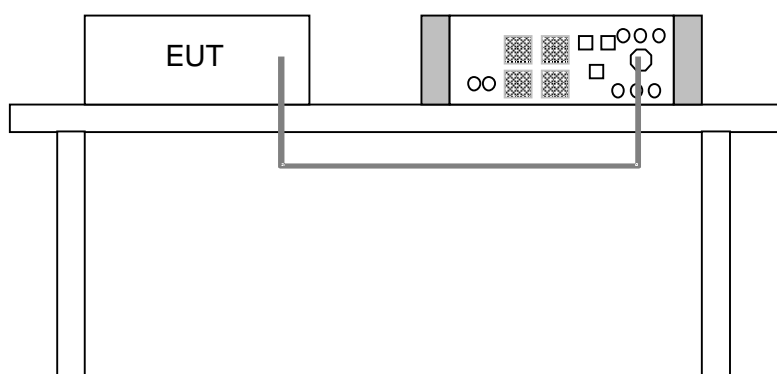

For the actual test configuration, please refer to the related item – Photographs of the Test Configuration.



4.4.6 EUT OPERATING CONDITIONS

- a. Connected NB with EUT via USB cable and RJ45 to RS232 cable.
- b. Set EUT under online mode.
- c. Turned on the power of all equipment.
- d. Notebook ran a test program to enable all functions.
- e. Notebook read and wrote messages from HDD.
- f. EUT sent and received messages to/from Notebook (kept in a remote area) with AP via an UTP LAN cable (10m).
- g. Notebook sent messages to panel and then panel displayed messages on its screen.
- n. Notebook run “short to ulSim-TreeView.BAT” via RS-232.
- h. Notebook keeps watch on Notebook’s device manager “APC UPS” via USB.
- i. Universal’s sensor keep watch on environment temperature.
- j. After test check EPO function.
- k. Steps e-j were repeated.



4.4.7 TEST RESULTS (1)

TEST MODE	Mode 2A		
FUNDAMENTAL VOLTAGE/AMPERE	230.1Vrms/ 12.33Arms	POWER FREQUENCY	49.987Hz
POWER CONSUMPTION	2835W	POWER FACTOR	0.999
ENVIRONMENTAL CONDITIONS	24deg. C, 66%RH	TESTED BY: Ken Chen	

Harm. Order	lavg (A)	lavg Limit (A)	Imax (A)	Imax Limit (A)	Harm. Order	lavg (A)	lavg Limit (A)	Imax (A)	Imax Limit (A)
1	12.2950	-	12.4760	-	2	0.0000	1.0800	0.0198	1.6200
3	0.0000	2.3000	0.0351	3.4500	4	0.0000	0.4300	0.0076	0.6450
5	0.0000	1.1400	0.0626	1.7100	6	0.0000	0.3000	0.0046	0.4500
7	0.0000	0.7700	0.0610	1.1550	8	0.0000	0.2300	0.0046	0.3450
9	0.0000	0.4000	0.0671	0.6000	10	0.0000	0.1840	0.0031	0.2760
11	0.0766	0.3300	0.0778	0.4950	12	0.0000	0.1533	0.0031	0.2300
13	0.0743	0.2100	0.0748	0.3150	14	0.0000	0.1314	0.0031	0.1971
15	0.0766	0.1500	0.0778	0.2250	16	0.0000	0.1150	0.0031	0.1725
17	0.0000	0.1324	0.0702	0.1985	18	0.0000	0.1022	0.0031	0.1533
19	0.0000	0.1184	0.0641	0.1776	20	0.0000	0.0920	0.0031	0.1380
21	0.0000	0.1071	0.0519	0.1607	22	0.0000	0.0836	0.0031	0.1255
23	0.0000	0.0978	0.0412	0.1467	24	0.0000	0.0767	0.0031	0.1150
25	0.0000	0.0900	0.0275	0.1350	26	0.0000	0.0708	0.0031	0.1062
27	0.0000	0.0833	0.0153	0.1250	28	0.0000	0.0657	0.0031	0.0986
29	0.0000	0.0776	0.0137	0.1164	30	0.0000	0.0613	0.0031	0.0920
31	0.0000	0.0726	0.0214	0.1089	32	0.0000	0.0575	0.0046	0.0863
33	0.0000	0.0682	0.0305	0.1023	34	0.0000	0.0541	0.0031	0.0812
35	0.0000	0.0643	0.0366	0.0964	36	0.0000	0.0511	0.0031	0.0767
37	0.0000	0.0608	0.0397	0.0912	38	0.0000	0.0484	0.0046	0.0726
39	0.0000	0.0577	0.0412	0.0865	40	0.0000	0.0460	0.0046	0.0690

NOTE: Steady state values on AC mains are recorded in the table.



4.4.8 TEST RESULTS (2)

TEST MODE	Mode 3A		
FUNDAMENTAL VOLTAGE/AMPERE	230.1Vrms/ 9.119Arms	POWER FREQUENCY	49.987Hz
POWER CONSUMPTION	2096W	POWER FACTOR	0.999
ENVIRONMENTAL CONDITIONS	24deg. C, 66%RH	TESTED BY: Ken Chen	

Harm. Order	lavg (A)	lavg Limit (A)	lmax (A)	lmax Limit (A)	Harm. Order	lavg (A)	lavg Limit (A)	lmax (A)	lmax Limit (A)
1	9.0759	-	9.1599	-	2	0.0000	1.0800	0.0214	1.6200
3	0.0000	2.3000	0.0504	3.4500	4	0.0000	0.4300	0.0046	0.6450
5	0.0007	1.1400	0.0534	1.7100	6	0.0000	0.3000	0.0046	0.4500
7	0.0000	0.7700	0.0458	1.1550	8	0.0000	0.2300	0.0061	0.3450
9	0.0000	0.4000	0.0488	0.6000	10	0.0000	0.1840	0.0046	0.2760
11	0.0586	0.3300	0.0595	0.4950	12	0.0000	0.1533	0.0061	0.2300
13	0.0595	0.2100	0.0595	0.3150	14	0.0000	0.1314	0.0031	0.1971
15	0.0641	0.1500	0.0641	0.2250	16	0.0000	0.1150	0.0046	0.1725
17	0.0599	0.1324	0.0610	0.1985	18	0.0000	0.1022	0.0031	0.1533
19	0.0590	0.1184	0.0595	0.1776	20	0.0000	0.0920	0.0031	0.1380
21	0.0001	0.1071	0.0519	0.1607	22	0.0000	0.0836	0.0046	0.1255
23	0.0000	0.0978	0.0458	0.1467	24	0.0000	0.0767	0.0031	0.1150
25	0.0000	0.0900	0.0366	0.1350	26	0.0000	0.0708	0.0031	0.1062
27	0.0000	0.0833	0.0290	0.1250	28	0.0000	0.0657	0.0031	0.0986
29	0.0000	0.0776	0.0198	0.1164	30	0.0000	0.0613	0.0046	0.0920
31	0.0000	0.0726	0.0122	0.1089	32	0.0000	0.0575	0.0046	0.0863
33	0.0000	0.0682	0.0092	0.1023	34	0.0000	0.0541	0.0046	0.0812
35	0.0000	0.0643	0.0107	0.0964	36	0.0000	0.0511	0.0031	0.0767
37	0.0000	0.0608	0.0153	0.0912	38	0.0000	0.0484	0.0031	0.0726
39	0.0000	0.0577	0.0183	0.0865	40	0.0000	0.0460	0.0031	0.0690

NOTE: Steady state values on AC mains are recorded in the table.

4.5 LIMITS OF VOLTAGE FLUCTUATION AND FLICKS MEASUREMENT

TEST STANDARD: IEC 61000-3-3

TEST ITEM	LIMIT	NOTE
P_{st}	1.0	P_{st} means short-term flicker indicator.
P_{lt}	0.65	P_{lt} means long-term flicker indicator.
$T_{d(t)}$ (ms)	500	$T_{d(t)}$ means maximum time that $d(t)$ exceeds 3.3%
d_{max} (%)	4	d_{max} means maximum relative voltage change.
dc (%)	3.3	dc means relative steady-state voltage change

4.5.1 TEST INSTRUMENTS

Description & Manufacturer	Model No.	Serial No.	Cal. Date	Cal. Due
EMC PARTNER EMC Emission Tester	HAR1000-1P	084	Apr. 24, 2015	Apr. 23, 2016
Software	HARCS	NA	NA	NA

Notes: 1. The calibration interval of the above test instruments is 12 months and the calibrations are traceable to NML/ROC and NIST/USA.
 2. The test was performed in EMS Room No. 2.
 3. Tested Date: May 8, 2015.

4.5.2 TEST PROCEDURE

- a. The EUT was placed on the top of a wooden table 0.8 meters above the ground and operated to produce the most unfavorable sequence of voltage changes under normal operating conditions.
- b. During the flick measurement, the measure time shall include that part of whole operation cycle in which the EUT produce the most unfavorable sequence of voltage changes. The observation period for short-term flicker indicator is 10 minutes and the observation period for long-term flicker indicator is 2 hours.

4.5.3 DEVIATION FROM TEST STANDARD

No deviation

4.5.4 TEST SETUP

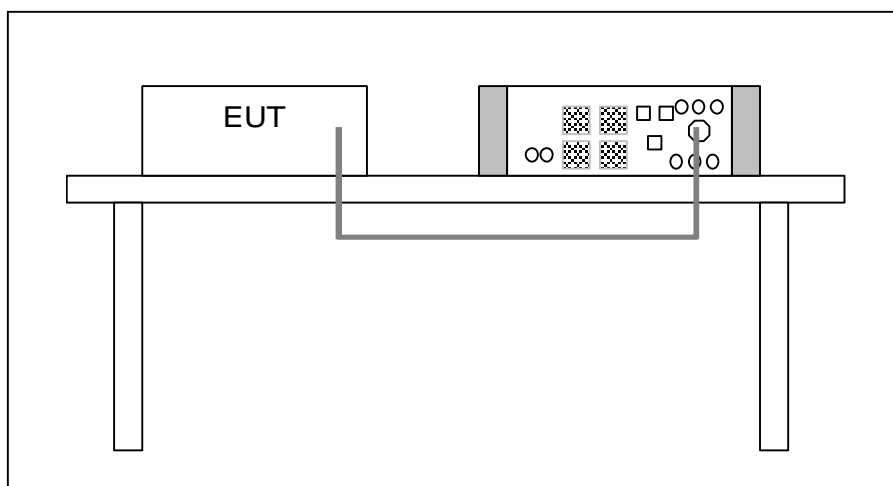

For the actual test configuration, please refer to the related item – Photographs of the Test Configuration.

4.5.5 EUT OPERATING CONDITIONS

Same as item 4.4.6.

4.5.6 TEST RESULTS (1)

TEST MODE	Mode 2A		
FUNDAMENTAL VOLTAGE/AMPERE	224.0Vrms/ 12.85Arms	POWER FREQUENCY	49.987Hz
OBSERVATION PERIOD (Tp)	10 minutes	POWER FACTOR	1.000
ENVIRONMENTAL CONDITIONS	24deg. C, 66% RH	TESTED BY: Ken Chen	

TEST PARAMETER	MEASUREMENT VALUE	LIMIT	REMARKS
P _{st}	0.072	1.0	Pass
P _{lt}	0.072	0.65	Pass
T _{d(t)} (ms)	0	500	Pass
d _{max} (%)	0.060	4	Pass
dc (%)	0.020	3.3	Pass

- NOTE:**
- (1) P_{st} means short-term flicker indicator.
 - (2) P_{lt} means long-term flicker indicator.
 - (3) T_{d(t)} means maximum time that d(t) exceeds 3.3%.
 - (4) d_{max} means maximum relative voltage change.
 - (5) dc means relative steady-state voltage change.

4.5.7 TEST RESULTS (2)

TEST MODE	Mode 3A		
FUNDAMENTAL VOLTAGE/AMPERE	225.8Vrms/ 9.241Arms	POWER FREQUENCY	49.987Hz
OBSERVATION PERIOD (Tp)	10 minutes	POWER FACTOR	0.998
ENVIRONMENTAL CONDITIONS	24deg. C, 66% RH	TESTED BY: Ken Chen	

TEST PARAMETER	MEASUREMENT VALUE	LIMIT	REMARKS
P _{st}	0.074	1.0	Pass
P _{lt}	0.074	0.65	Pass
T _{d(t)} (ms)	0	500	Pass
d _{max} (%)	0	4	Pass
dc (%)	0.120	3.3	Pass

- NOTE:**
- (1) P_{st} means short-term flicker indicator.
 - (2) P_{lt} means long-term flicker indicator.
 - (3) T_{d(t)} means maximum time that d(t) exceeds 3.3%.
 - (4) d_{max} means maximum relative voltage change.
 - (5) dc means relative steady-state voltage change.

5 IMMUNITY TEST

5.1 GENERAL DESCRIPTION OF EN 62040-2

Product Standard:	EN 62040-2:2006, Category C2	
Basic Standard, specification requirement, and Performance Criteria:	IEC 61000-4-2	Electrostatic Discharge – ESD: 8kV air discharge, 4kV Contact discharge, Performance Criterion B
	IEC 61000-4-3	Radio-Frequency Electromagnetic Field Amplitude modulated – RS: 80-1000 MHz, 3V/m, 80% AM (1kHz), Performance Criterion A
	IEC 61000-4-4	Electrical Fast Transient/Burst - EFT AC Power line: 1kV, DC Power line: 1kV Signal line: 1kV Performance Criterion B
	IEC 61000-4-5	Surge Immunity Test: 1.2/50 us Open Circuit Voltage, 8 /20 us Short Circuit Current AC Power Line: line to line 1 kV, line to earth 2kV Signal line: line to earth 1kV Performance Criterion B
	IEC 61000-4-6	Conducted Radio Frequency Disturbances Test – CS: 0.15-80 MHz, 3Vrms, 80% AM, 1kHz, Performance Criterion A
	IEC 61000-4-8	Power Frequency Magnetic Field Test, 50 Hz, 30A/m, Performance Criterion A
	IEC 61000-2-2	Immunity to low-frequency signals Test: 140-360 Hz, 10Vrms Performance Criterion A

5.2 SPECIFIC IMMUNITY REQUIREMENTS BY MANUFACTURER

Immunity requirements		
Reference standard	Test specification	Performance Criterion
IEC 61000-4-3 RS	80-6000 MHz, 10V/m, 80% AM (1kHz)	A
IEC 61000-4-4 EFT	AC Power line: 2Kv Signal line: 2V	B
IEC 61000-4-5 Surge	Signal line: line to earth 2kV	B
IEC 61000-4-6 CS	0.15-80 MHz, 10Vrms, 80% AM, 1kHz	A
IEC 61000-4-11 Dips & Interruptions	Voltage Dips: >95% reduction – 0.5 period >95% reduction – 1 period 30% reduction – 25 periods Voltage Interruptions: >95% reduction – 250 periods	B

5.3 GENERAL PERFORMANCE CRITERIA DESCRIPTION

According to Clause 7 of EN 62040-2 standard, the following describes the general performance criteria.

Performance Criteria	OUTPUT CHARACTERISTICS	EXTERNAL AND INTERNAL INDICATIONS AND METERING	CONTROL SIGNALS TO EXTERNAL DEVICES	MODE OF OPERATION
A	Voltage permitted to vary only within the steady-state characteristics applicable (100m sec limits in Figures 1, 2 or 3 of IEC62040-3)	Change only during test	No change	No change
B	Voltage permitted to vary within the inverse time characteristics applicable (<100m sec limits in Figures 1, 2 or 3 of IEC62040-3)	Change only during test	Change only temporarily in consistency with the actual UPS mode of operation	Change only temporarily

5.4 EUT OPERATING CONDITION

Same as item 4.4.6.



5.5 ELECTROSTATIC DISCHARGE IMMUNITY TEST (ESD)

5.5.1 TEST SPECIFICATION

Basic Standard:	IEC 61000-4-2
Discharge Impedance:	330 ohm / 150 pF
Discharge Voltage:	Air Discharge: 2kV/ 4kV/ 8kV (Direct) Contact Discharge: 2kV/ 4kV (Direct/ Indirect)
Polarity:	Positive & Negative
Number of Discharge:	20 times at each test point
Discharge Mode:	Single Discharge
Discharge Period:	1 second minimum

5.5.2 TEST INSTRUMENTS

Description & Manufacturer	Model No.	Serial No.	Cal. Date	Cal. Due
KeyTek, ESD Simulator	MZ-15/EC	1203252	Jul. 24, 2014	Jul. 23, 2015

- Notes:
1. The calibration interval of the above test instruments is 12 months and the calibrations are traceable to NML/ROC and NIST/USA.
 2. The test was performed in ESD Room No. 2.
 3. Tested Date: May 13, 2015.

5.5.3 TEST PROCEDURE

The basic test procedure was in accordance with IEC 61000-4-2:

- a. Electrostatic discharges were applied only to those points and surfaces of the EUT that are accessible to users during normal operation.
- b. The test was performed with at least ten single discharges on the pre-selected points in the most sensitive polarity.
- c. The time interval between two successive single discharges was at least 1 second.
- d. The ESD generator was held perpendicularly to the surface to which the discharge was applied and the return cable was at least 0.2 meters from the EUT.
- e. Contact discharges were applied to the non-insulating coating, with the pointed tip of the generator penetrating the coating and contacting the conducting substrate.
- f. Air discharges were applied with the round discharge tip of the discharge electrode approaching the EUT as fast as possible (without causing mechanical damage) to touch the EUT. After each discharge, the ESD generator was removed from the EUT and re-triggered for a new single discharge. The test was repeated until all discharges were complete.
- g. At least ten single discharges (in the most sensitive polarity) were applied to the **Horizontal Coupling Plane** at points on each side of the EUT. The ESD generator was positioned horizontally at a distance of 0.1 meters from the EUT with the discharge electrode touching the **HCP**.
- h. At least ten single discharges (in the most sensitive polarity) were applied to the center of one vertical edge of the **Vertical Coupling Plane** in sufficiently different positions that the four faces of the EUT were completely illuminated. The **VCP** (dimensions 0.5m x 0.5m) was placed vertically to and 0.1 meters from the EUT.

5.5.4 DEVIATION FROM TEST STANDARD

No deviation

5.5.5 TEST SETUP

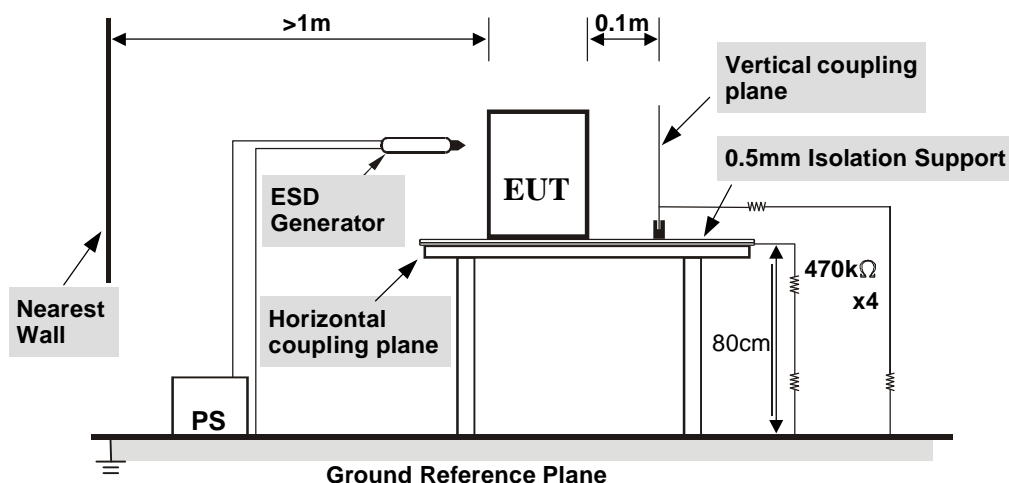

For the actual test configuration, please refer to the related item – Photographs of the Test Configuration.

NOTE:

TABLE-TOP EQUIPMENT

The configuration consisted of a wooden table 0.8 meters high standing on the **Ground Reference Plane**. The **GRP** consisted of a sheet of aluminum at least 0.25mm thick, and 2.5 meters square connected to the protective grounding system. A **Horizontal Coupling Plane** (1.6m x 0.8m) was placed on the table and attached to the **GRP** by means of a cable with 940kΩ total impedance. The equipment under test, was installed in a representative system as described in section 7 of IEC 61000-4-2, and its cables were placed on the **HCP** and isolated by an insulating support of 0.5mm thickness. A distance of 1-meter minimum was provided between the EUT and the walls of the laboratory and any other metallic structure.

FLOOR-STANDING EQUIPMENT

The equipment under test was installed in a representative system as described in section 7 of IEC 61000-4-2, and its cables were isolated from the Ground Reference Plane by an insulating support of 0.1-meter thickness. The GRP consisted of a sheet of aluminum that is at least 0.25mm thick, and 2.5 meters square connected to the protective grounding system and extended at least 0.5 meters from the EUT on all sides.



5.5.6 TEST RESULTS (1)

TEST MODE	Mode 2A	INPUT POWER	230Vac, 50 Hz
ENVIRONMENTAL CONDITIONS	24deg. C, 55% RH, 1004mbar	TESTED BY: Ken Chen	

TEST RESULTS OF DIRECT APPLICATION					
Discharge Level (kV)	Polarity (+/-)	Test Point	Contact Discharge	Air Discharge	Performance Criterion
2, 4	+/-	1-3	Note 2	N/A	B
2, 4, 8	+/-	4-6, 8-9	N/A	Note 1	A
2, 4	+/-	7	N/A	Note 1	A
8	+/-	7	N/A	Note 2	B

Description of test point: Please refer to ESD test photo for representative mark only.

TEST RESULTS OF INDIRECT APPLICATION					
Discharge Level (kV)	Polarity (+/-)	Test Point	Horizontal Coupling Plane	Vertical Coupling Plane	Performance Criterion
2, 4	+/-	1-4	Note 2	Note 2	B

Description of test point:

1. Left side
2. Right side
3. Front side
4. Rear side

NOTE: (1) There was no change compared with initial operation during the test.
 (2) The signal of panel disappeared during the test, but auto recover itself after the test.



5.5.7 TEST RESULTS (2)

TEST MODE	Mode 3A	INPUT POWER	230Vac, 50 Hz
ENVIRONMENTAL CONDITIONS	24deg. C, 55% RH, 1004mbar	TESTED BY: Ken Chen	

TEST RESULTS OF DIRECT APPLICATION					
Discharge Level (kV)	Polarity (+/-)	Test Point	Contact Discharge	Air Discharge	Performance Criterion
2, 4	+/-	1-3	Note 2	N/A	B
2, 4, 8	+/-	4-6, 8-9	N/A	Note 1	A
2, 4	+/-	7	N/A	Note 1	A
8	+/-	7	N/A	Note 2	B

Description of test point: Please refer to ESD test photo for representative mark only.

TEST RESULTS OF INDIRECT APPLICATION					
Discharge Level (kV)	Polarity (+/-)	Test Point	Horizontal Coupling Plane	Vertical Coupling Plane	Performance Criterion
2, 4	+/-	1-4	Note 2	Note 2	B

Description of test point:

- 5. Left side
- 6. Right side
- 7. Front side
- 8. Rear side

NOTE: (1) There was no change compared with initial operation during the test.
 (2) The signal of panel disappeared during the test, but auto recover itself after the test.



5.6 RADIATED, RADIO-FREQUENCY, ELECTROMAGNETIC FIELD IMMUNITY TEST (RS)

5.6.1 TEST SPECIFICATION

Basic Standard:	IEC 61000-4-3
Frequency Range:	80 MHz - 3000 MHz for Antenna Height: 1.5m 3000 MHz - 6000 MHz for Antenna Height: 1.25m
Field Strength:	10 V/m
Modulation:	1kHz Sine Wave, 80%, AM Modulation
Frequency Step:	1 % of fundamental
Polarity of Antenna:	Horizontal and Vertical
Dwell Time:	3 seconds

5.6.2 TEST INSTRUMENTS

Description & Manufacturer	Model No.	Serial No.	Cal. Date	Cal. Due
Agilent Signal Generator	E8257D	MY48050465	Jul. 18, 2014	Jul. 17, 2015
PRANA RF Amplifier	AP32DP280	0811-894	NA	NA
AR RF Amplifier	150W1000M3	306601	NA	NA
AR RF Amplifier	35S4G8AM4	0326094	NA	NA
AR RF Amplifier	100S1G4M3	0329249	NA	NA
AR Controller	SC1000M3	305910	NA	NA
Radisense Electric Field Sensor	CTR1002A	08D00057SNO-07	Oct. 13, 2014	Oct. 12, 2015
BOONTON RF Voltage Meter	4232A	10180	Jun. 04, 2014	Jun. 03, 2015
BOONTON Power Sensor	51011-EMC	34152	Jun. 05, 2014	Jun. 04, 2015
BOONTON Power Sensor	51011-EMC	34153	Jun. 05, 2014	Jun. 04, 2015
AR Log-Periodic Antenna	AT6080	0329465	NA	NA
EMCO BiconiLog Antenna	3141	1001	NA	NA
AR High Gain Antenna	AT4002A	306533	NA	NA
AR High Gain Horn Antenna	AT4010	0329800	NA	NA
CHANCE MOST Full Anechoic Chamber (9x5x3m)	Chance Most	RS-002	Feb. 05, 2015	Feb. 04, 2016
Software	ADT_RS_V7.6	NA	NA	NA

- Notes:
1. The calibration interval of the above test instruments is 12 months and the calibrations are traceable to NML/ROC and NIST/USA.
 2. The test was performed in RS Room No.2.
 3. Tested Date: May 13, 2015.

5.6.3 TEST PROCEDURE

The test procedure was in accordance with IEC 61000-4-3

- The testing was performed in a fully-anechoic chamber.
- The frequency range is swept from 80 MHz to 6000 MHz with the signal 80% amplitude modulated with a 1kHz sine wave.
- The dwell time at each frequency shall not be less than the time necessary for the EUT to be exercised and to respond, but shall in no case be less than 0,5s.
- The field strength level was 10V/m.
- The test was performed with the EUT exposed to both vertically and horizontally polarized fields on each of the four sides.

5.6.4 DEVIATION FROM TEST STANDARD

The requirement followed by the client's specification. (Refer to item 5.2)

5.6.5 TEST SETUP

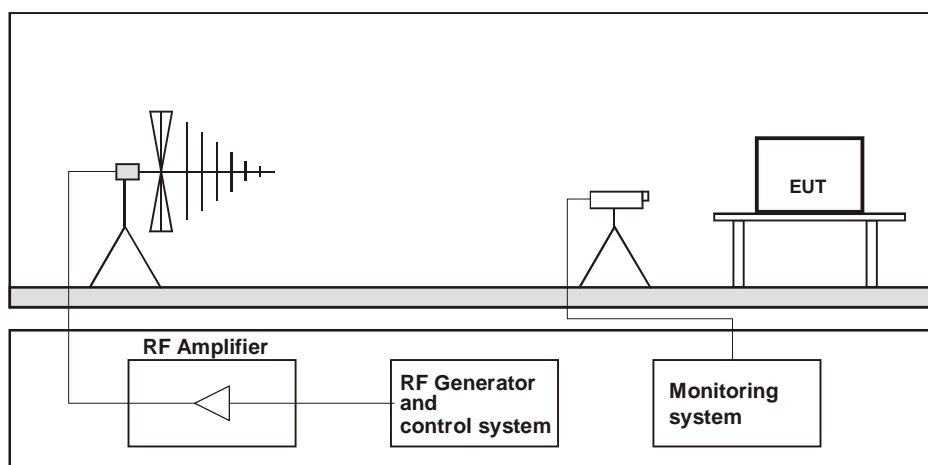

For the actual test configuration, please refer to the related item – Photographs of the Test Configuration.

NOTE:

TABLETOP EQUIPMENT

The EUT installed in a representative system as described in section 7 of IEC 61000-4-3 was placed on a non-conductive table 0.8 meters in height. The system under test was connected to the power and signal wire according to relevant installation instructions.

FLOOR STANDING EQUIPMENT

The EUT installed in a representative system as described in section 7 of IEC 61000-4-3 was placed on a non-conductive wood support 0.1 meters in height. The system under test was connected to the power and signal wire according to relevant installation instructions.



5.6.6 TEST RESULTS

TEST MODE	Mode 2A & Mode 3A	INPUT POWER	230Vac, 50Hz
ENVIRONMENTAL CONDITIONS	24deg. C, 69% RH	TESTED BY: Ken Chen	

Frequency (MHz)	Polarity	Azimuth	Field Strength (V/m)	Observation	Performance Criterion
80 -3000	V&H	0°, 90°, 180°, 270° (Antenna High 1.5m)	10	Note	A
3000 -6000	V&H	0°, 90°, 180°, 270° (Antenna High 1.25m)	10	Note	A

NOTE: There was no change compared with the initial operation during the test.



A D T

5.7 ELECTRICAL FAST TRANSIENT/BURST IMMUNITY TEST (EFT)

5.7.1 TEST SPECIFICATION

Basic Standard:	IEC 61000-4-4
Test Voltage:	Power Line: 2 kV Signal Line: 2 kV
Polarity:	Positive & Negative
Impulse Frequency:	5 kHz
Impulse Waveshape :	5/50 ns
Burst Duration:	15 ms
Burst Period:	300 ms
Test Duration:	1 min.

5.7.2 TEST INSTRUMENTS

Description & Manufacturer	Model No.	Serial No.	Cal. Date	Cal. Due
TESEQ, EFT Simulator	NSG 3060	1572	May 20, 2014	May 19, 2015
TESEQ, CDN	CDN 3083-B100	303	May 20, 2014	May 19, 2015
Haefely, Capacitive Clamp	IP4A	155173	Apr. 17, 2015	Apr. 16, 2016

- Notes: 1. The calibration interval of the above test instruments is 12 months and the calibrations are traceable to NML/ROC and NIST/USA.
2. The test was performed in EMS Room No. 2.
3. Tested Date: May 11, 2015.

5.7.3 TEST PROCEDURE

- The transient/burst waveform was in accordance with IEC 61000-4-4, 5/50ns.
- Both positive and negative polarity discharges were applied.
- The distance between any coupling devices and the EUT should be 0.5 m for table-top equipment testing, and 1.0 m for floor standing equipment.
- The duration time of each test sequential was 1 minute.
- The transient/burst waveform was in accordance with IEC 61000-4-4, 5/50 ns.

5.7.4 DEVIATION FROM TEST STANDARD

The requirement followed by the client's specification. (Refer to item 5.2)

5.7.5 TEST SETUP

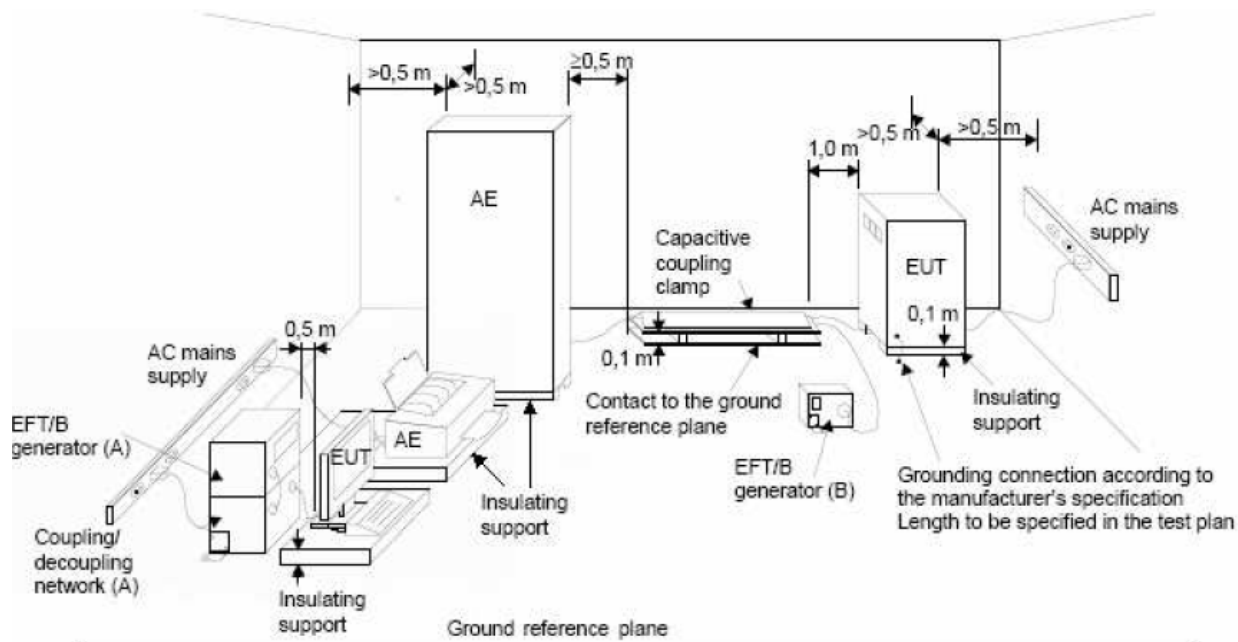

NOTE:

- (A) location for supply line coupling
- (B) location for signal lines coupling

For the actual test configuration, please refer to the related item – Photographs of the Test Configuration.

5.7.6 TEST RESULTS

TEST MODE	Mode 2A & 3A	INPUT POWER	230Vac, 50Hz
ENVIRONMENTAL CONDITIONS	25deg. C, 65% RH	TESTED BY: Ken Chen	

Test Point	Polarity	Test Level (kV)	Observation	Performance Criterion
For AC in test				
L	+/-	2	Note	B
N	+/-	2	Note	B
PE	+/-	2	Note	B
L-N-PE	+/-	2	Note	B
For AC out test				
L-N-PE	+/-	2	Note	B

Signal / telecommunication port

Test Point	Polarity	Test Level (kV)	Observation	Performance Criterion
RS232	+/-	2	Note	B
Cat.5 Line (NMC)	+/-	2	Note	B
USB	+/-	2	Note	B
EPO	+/-	2	Note	B
Universal *2	+/-	2	Note	B

NOTE: LAN & RS232 were disconnected during the test, but could self-recover after the test.



5.8 SURGE IMMUNITY TEST

5.8.1 TEST SPECIFICATION

Basic Standard:	IEC 61000-4-5
Wave-Shape:	Combination Wave 1.2/50 us Open Circuit Voltage 8 /20 us Short Circuit Current
Test Voltage:	Power Line : 0.5 kV / 1 kV / 2 kV Signal Line : 0.5 kV / 1 kV / 2 kV
Generator Source Impedance:	2 ohm between networks 12 ohm between network and ground 40 ohm between signal and ground
Polarity:	Positive/Negative
Phase Angle:	0° /90°/180°/270°
Pulse Repetition Rate:	1 time / 20 sec.
Number of Tests:	5 positive and 5 negative at selected points

5.8.2 TEST INSTRUMENTS

For AC in & signal port test:

Description & Manufacturer	Model No.	Serial No.	Cal. Date	Cal. Due
KeyTek, Surge Simulator	EMC Pro	9902207	May 15, 2014	May 14, 2015
Coupling Decoupling Network	CDN-UTP8	028	Aug. 18, 2014	Aug. 17, 2015
Software	CEWare32	NA	NA	NA

- Notes: 1. The calibration interval of the above test instruments is 12 months and the calibrations are traceable to NML/ROC and NIST/USA.
2. The test was performed in Surge Room.
3. Tested Date: May 11, 2015.

For AC out test:

Description & Manufacturer	Model No.	Serial No.	Cal. Date	Cal. Due
TESEQ, Surge Simulator	NSG 3060	1572	May 20, 2014	May 19, 2015
TESEQ, CDN	CDN 3083-100	1215	May 20, 2014	May 19, 2015
Coupling Decoupling Network	CDN-UTP8	028	Aug. 18, 2014	Aug. 17, 2015

- Notes: 1. The calibration interval of the above test instruments is 12 months and the calibrations are traceable to NML/ROC and NIST/USA.
2. The test was performed in EMS Room No. 2.
3. Tested Date: May 11, 2015.

5.8.3 TEST PROCEDURE

a. For EUT power supply:

The surge is to be applied to the EUT power supply terminals via the capacitive coupling network. Decoupling networks are required in order to avoid possible adverse effects on equipment not under test that may be powered by the same lines, and to provide sufficient decoupling impedance to the surge wave. The power cord between the EUT and the coupling/decoupling networks shall be 2 meters in length (or shorter).

b. For test applied to unshielded unsymmetrically operated interconnection lines of EUT:

The surge is applied to the lines via the capacitive coupling. The coupling / decoupling networks shall not influence the specified functional conditions of the EUT. The interconnection line between the EUT and the coupling/decoupling networks shall be 2 meters in length (or shorter).

c. For test applied to unshielded symmetrically operated interconnection / telecommunication lines of EUT:

The surge is applied to the lines via gas arrestors coupling. Test levels below the ignition point of the coupling arrestor cannot be specified. The interconnection line between the EUT and the coupling/decoupling networks shall be 2 meters in length (or shorter).

5.8.4 DEVIATION FROM TEST STANDARD

The requirement followed by the client’s specification. (Refer to item 5.2)

5.8.5 TEST SETUP

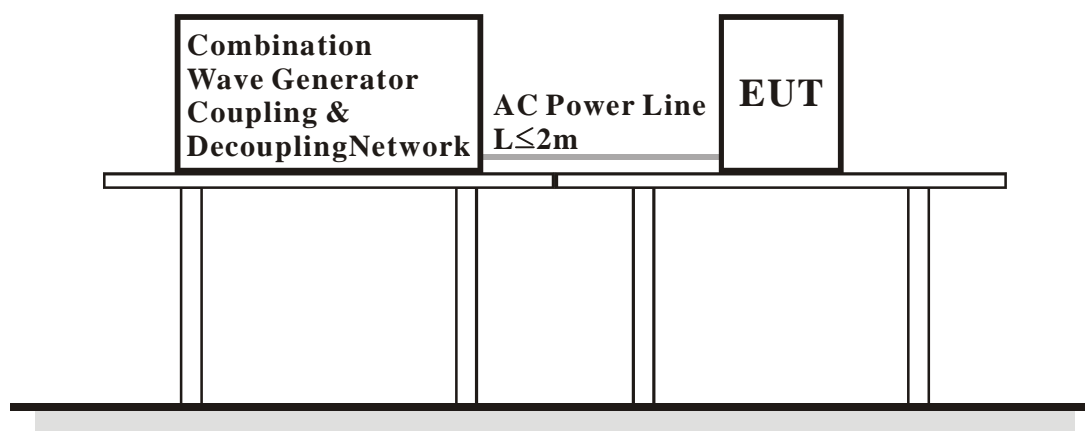

For the actual test configuration, please refer to the related item – Photographs of the Test Configuration.



A D T

5.8.6 TEST RESULTS

TEST MODE	Mode 2A & Mode 3A	INPUT POWER	230Vac, 50Hz
ENVIRONMENTAL CONDITIONS	25deg. C, 65% RH	TESTED BY: Ken Chen	

Voltage (kV)	Test Point	Polarity (+/-)	Phase Angle				Performance Criterion
			0°	90°	180°	270°	
For AC in test							
0.5, 1	L-N	+	Note 1	Note 1	Note 1	Note 1	A
		-	Note 1	Note 1	Note 1	Note 1	A
0.5, 1, 2	L-PE	+	Note 1	Note 1	Note 1	Note 1	A
		-	Note 1	Note 1	Note 1	Note 1	A
	N-PE	+	Note 1	Note 1	Note 1	Note 1	A
		-	Note 1	Note 1	Note 1	Note 1	A
For AC out test							
0.5, 1	L-N	+	Note 1	Note 1	Note 1	Note 1	A
		-	Note 1	Note 1	Note 1	Note 1	A
0.5, 1, 2	L-PE	+	Note 1	Note 1	Note 1	Note 1	A
		-	Note 1	Note 1	Note 1	Note 1	A
	N-PE	+	Note 1	Note 1	Note 1	Note 1	A
		-	Note 1	Note 1	Note 1	Note 1	A

Signal / telecommunication port

Voltage (kV)	Test Point	Polarity (+/-)	Observation	Performance Criterion
0.5, 1, 2	LAN (NMC)	+	Note 2	B
		-	Note 2	B

NOTE:

- (1) There was no change compared with the initial operation during the test.
- (2) LAN was disconnected during the test, but could self-recover after the test.



5.9 IMMUNITY TO CONDUCTED DISTURBANCES INDUCED BY RF FIELDS (CS)

5.9.1 TEST SPECIFICATION

Basic Standard:	IEC 61000-4-6
Frequency Range:	0.15 MHz - 80 MHz
Field Strength:	10 V _{r.m.s.}
Modulation:	1kHz Sine Wave, 80%, AM Modulation
Frequency Step:	1 % of fundamental

5.9.2 TEST INSTRUMENTS

Description & Manufacturer	Model No.	Serial No.	Cal. Date	Cal. Due
ROHDE & SCHWARZ Signal Generator	SML03	101801	Jan. 05, 2015	Jan. 04, 2016
Digital Sweep Function Generator	8120	984801	NA	NA
AR Power Amplifier	75A250AM1	312196	NA	NA
FCC Coupling Decoupling Network	FCC-801-M3-25A	48	Jun. 23, 2014	Jun. 22, 2015
FCC Coupling Decoupling Network	FCC-801-M3-25A	01022	Jun. 23, 2014	Jun. 22, 2015
FCC Coupling Decoupling Network	FCC-801-M2-16A	01047	Jun. 23, 2014	Jun. 22, 2015
FISCHER CUSTOM COMMUNICATIONS EM Injection Clamp	FCC-203I	50	NA	NA
FISCHER CUSTOM COMMUNICATIONS Current Injection Clamp	F-120-9A	361	NA	NA
EM TEST Coupling Decoupling Network	CDN M1/32A	306508	Jun. 23, 2014	Jun. 22, 2015
TESEQ Coupling Decoupling Network	CDN T800	34428	Jun. 23, 2014	Jun. 22, 2015
FCC Coupling Decoupling Network	FCC-801-T4	02031	Jun. 23, 2014	Jun. 22, 2015
FCC Coupling Decoupling Network	FCC-801-T2	02021	Jun. 23, 2014	Jun. 22, 2015
R&S Power Sensor	NRV-Z5	837878/039	Oct. 28, 2014	Oct. 27, 2015
R&S Power Meter	NRVD	837794/040	Oct. 28, 2014	Oct. 27, 2015
Software	ADT_CS_V7.4.2	NA	NA	NA

- Notes:
1. The calibration interval of the above test instruments is 12 months and the calibrations are traceable to NML/ROC and NIST/USA.
 2. The test was performed in CS Room No. 1.
 3. Tested Date: May 8, 2015.

5.9.3 TEST PROCEDURE

- a. The EUT shall be tested within its intended operating and climatic conditions.
- b. An artificial hand was placed on the hand-held accessory and connected to the ground reference plane.
- c. One of the CDNs not used for injection was terminated with 50Ω , providing only one return path. All other CDNs were coupled as decoupling networks.
- d. The frequency range is swept from 150 kHz to 80 MHz, using the signal level established during the setting process and with a disturbance signal of 80 % amplitude. The signal is modulated with a 1 kHz sine wave, pausing to adjust the RF signal level or the switch coupling devices as necessary. Where the frequency is swept incrementally, the step size shall not exceed 1 % of the preceding frequency value.
- e. The dwell time of the amplitude modulated carrier at each frequency shall not be less than the time necessary for the EUT to be exercised and to respond, but shall in no case be less than 0,5 s. The sensitive frequencies (e.g. clock frequencies) shall be analyzed separately.
- f. Attempts should be made to fully exercise the EUT during testing, and to fully interrogate all exercise modes selected for susceptibility.

5.9.4 DEVIATION FROM TEST STANDARD

The requirement followed by the client's specification. (Refer to item 5.2)

5.9.5 TEST SETUP

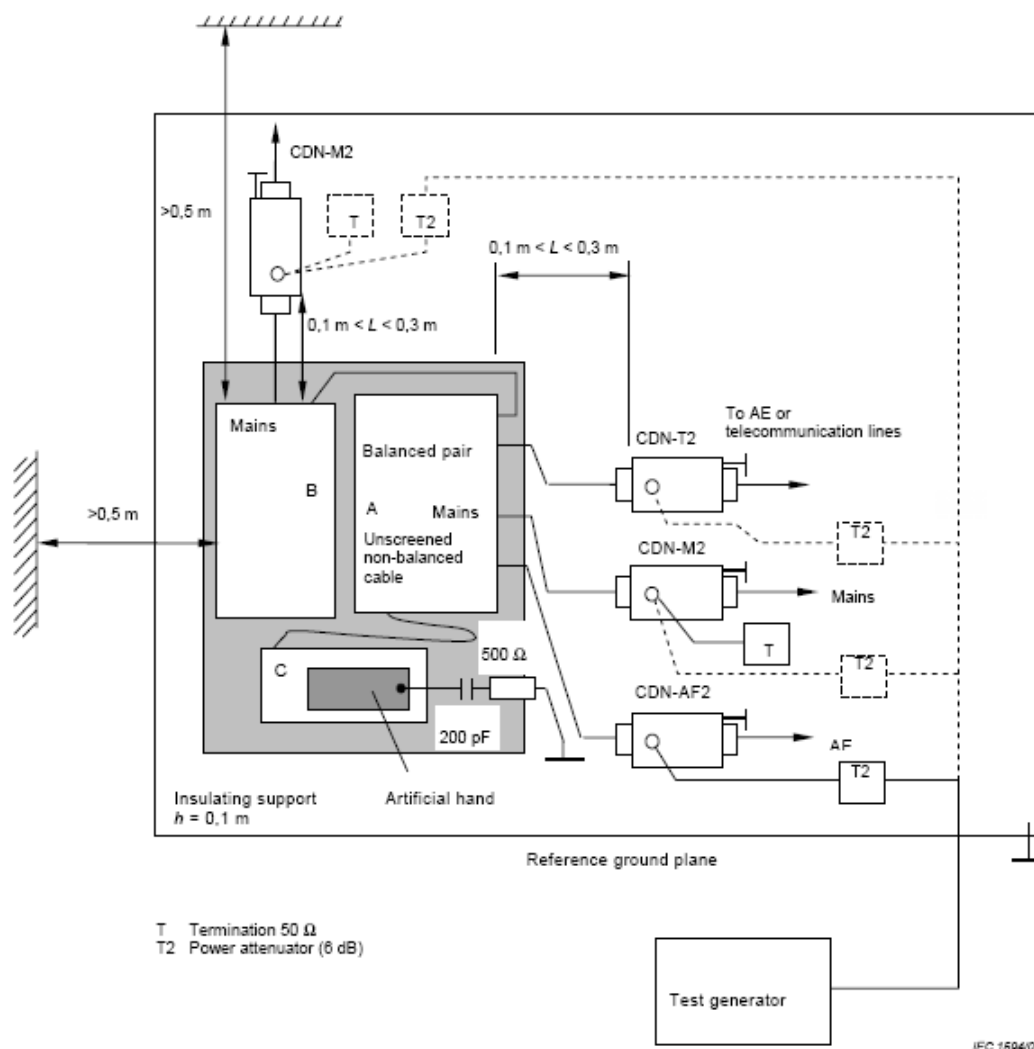

- Note:**
1. The EUT clearance from any metallic obstacles shall be at least 0,5 m.
 2. Interconnecting cables (≤ 1 m) belonging to the EUT shall remain on the insulating support.
 3. The equipment to be tested is placed on an insulating support of 0.1 meters height above a ground reference plane. All relevant cables shall be provided with the appropriate coupling and decoupling devices at a distance between 0.1 meters and 0.3 meters from the projected geometry of the EUT on the ground reference plane.

For the actual test configuration, please refer to the related item – Photographs of the Test Configuration.



5.9.6 TEST RESULTS

TEST MODE	Mode 2A & Mode 3A	INPUT POWER	230Vac, 50Hz
ENVIRONMENTAL CONDITIONS	26deg. C, 68% RH	TESTED BY: Louis Liao	

Frequency (MHz)	Field Strength (V _{r.m.s.})	Cable	Injection Method	RETURN PATH	Observation	Performance Criterion
0.15 – 80	10	AC in	CDN-M3	CDN-T4	Note	A
0.15 – 80	10	AC out	CLAMP	CDN-T4	Note	A
0.15 – 80	10	LAN (NMC)	CDN-T4	CDN-M3	Note	A
0.15 – 80	10	USB	CLAMP	CDN-T4	Note	A
0.15 – 80	10	RS232	CLAMP	CDN-T4	Note	A
0.15 – 80	10	EPO	CLAMP	CDN-T4	Note	A
0.15 – 80	10	Universal *2	CLAMP	CDN-T4	Note	A

NOTE: There was no change compared with the initial operation during the test.



5.10 POWER FREQUENCY MAGNETIC FIELD IMMUNITY TEST

5.10.1 TEST SPECIFICATION

Basic Standard:	IEC 61000-4-8
Frequency Range:	50Hz/ 60Hz
Field Strength:	30 A/m
Observation Time:	1 minute
Inductance Coil:	Rectangular type, 1mx1m

5.10.2 TEST INSTRUMENTS

Description & Manufacturer	Model No.	Serial No.	Cal. Date	Cal. Due
HAEFELY Magnetic Field Tester	MAG 100	083794-06	NA	NA
COMBINOVA Magnetic Field Meter	MFM10	224	Apr. 24, 2015	Apr. 23, 2016

- Notes:
1. The calibration interval of the above test instruments is 12 months and the calibrations are traceable to NML/ROC and NIST/USA.
 2. The test was performed in EMS Room No. 1
 3. Tested Date: May 12, 2015.

5.10.3 TEST PROCEDURE

- a. The equipment is configured and connected to satisfy its functional requirements.
- b. The power supply, input and output circuits shall be connected to the sources of power supply, control and signal.
- c. The cables supplied or recommended by the equipment manufacturer shall be used. 1 meter of all cables used shall be exposed to the magnetic field.

5.10.4 DEVIATION FROM TEST STANDARD

No deviation

5.10.5 TEST SETUP

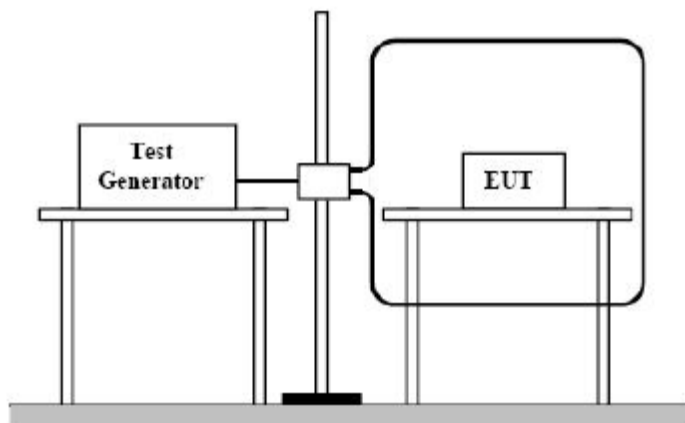

For the actual test configuration, please refer to the related item – Photographs of the Test Configuration.

NOTE:

TABLETOP EQUIPMENT

The equipment shall be subjected to the test magnetic field by using the induction coil of standard dimension (1 m x 1 m). The induction coil shall then be rotated by 90 degrees in order to expose the EUT to the test field with different orientations.

FLOOR-STANDING EQUIPMENT

The equipment shall be subjected to the test magnetic field by using induction coils of suitable dimensions. The test shall be repeated by moving and shifting the induction coils, in order to test the whole volume of the EUT for each orthogonal direction. The test shall be repeated with the coil shifted to different positions along the side of the EUT, in steps corresponding to 50 % of the shortest side of the coil. The induction coil shall then be rotated by 90 degrees in order to expose the EUT to the test field with different orientations.



5.10.6 TEST RESULTS

TEST MODE	Mode 2A & Mode 3A	INPUT POWER	230Vac, 50Hz
ENVIRONMENTAL CONDITIONS	24deg. C, 59% RH	TESTED BY: Ken Chen	

Direction	Field Strength (A/m)	Observation	Performance Criterion
X - Axis	30	Note	A
Y - Axis	30	Note	A
Z - Axis	30	Note	A

NOTE: There was no change compared with the initial operation during the test.

5.11 VOLTAGE DIPS AND INTERRUPTIONS

5.11.1 TEST SPECIFICATION

Basic Standard:	IEC 61000-4-11
Test levels:	Voltage Dips: >95% reduction – 0.5 period, Performance Criterion B >95% reduction – 1 period, Performance Criterion B 30% reduction – 25 periods, Performance Criterion B Voltage Interruptions: >95% reduction – 250 periods, Performance Criterion B
Interval between Event:	Minimum ten seconds
Sync Angle (degrees):	0° / 180°
Test Cycle:	3 times

5.11.2 TEST INSTRUMENTS

Description & Manufacturer	Model No.	Serial No.	Cal. Date	Cal. Due
KeyTek, PQF Generator	EMC Pro	9902207	May. 15, 2014	May. 14, 2015

- Notes: 1. The calibration interval of the above test instruments is 12 months and the calibrations are traceable to NML/ROC and NIST/USA.
2. The test was performed in EMS Room No. 1.
3. Tested Date: May 11, 2015.

5.11.3 TEST ARRANGEMENT

The EUT shall be tested for each selected combination of test levels and duration with a sequence of 3 dips/interruptions with intervals of 10 s minimum (between each test event). Each representative mode of operation shall be tested. Abrupt changes in supply voltage shall occur at 0 degree crossover point of the voltage waveform.

5.11.4 SUPPLEMENTARY INFORMATION

No deviation.

5.11.5 TEST SETUP

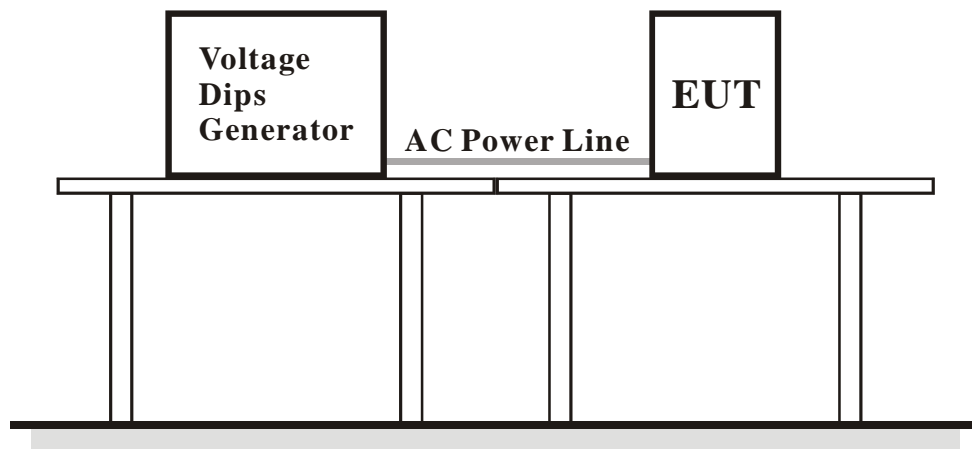

For the actual test configuration, please refer to the related item – Photographs of the Test Configuration.



5.11.6 TEST RESULTS

TEST MODE	Mode 2A & Mode 3A	INPUT POWER	230Vac, 50Hz
ENVIRONMENTAL CONDITIONS	25deg. C, 65% RH	TESTED BY: Ken Chen	

Input Power for testing: 230Vac, 50Hz			
VOLTAGE % REDUCTION	PERIOD	OBSERVATION	PERFORMANCE CRITERION
>95	0.5	Note	B
>95	1	Note	B
30	25	Note	B
>95	250	Note	B

Note: AC to battery, but could self-recover after the test.

5.12 IMMUNITY TO LOW-FREQUENCY SIGNALS

5.12.1 TEST SPECIFICATION

Basic Standard:	IEC 61000-2-2
Frequency Range:	140 Hz - 360 Hz
Field Strength:	10 V _{r.m.s.}
Frequency Step:	1 Hz
Coupled Cable:	Power Mains
Dwell Time:	at least 3 second

5.12.2 TEST INSTRUMENTS

Description & Manufacturer	Model No.	Serial No.	Cal. Date	Cal. Due
AC Power Supply KIKUSUI	PCR4000L	9508355	NA	NA
Voltage Meter FLUKE	179	89610322	Sep. 05, 2014	Sep. 04, 2015

- Notes:
1. The calibration interval of the above test instruments is 12 months and the calibrations are traceable to NML/ROC and NIST/USA.
 2. The test was performed in EMS Room No. 1.
 3. Tested Date: May 12, 2015.

5.12.3 TEST PROCEDURE

The test procedure was in accordance with IEC 61000-2-2

As a minimum, EUT was tested with disturbing voltage of 10V_{r.m.s.}, at a frequency, which is slowly varied from 140Hz to 360Hz.

5.12.4 DEVIATION FROM TEST STANDARD

No deviation

5.12.5 TEST SETUP

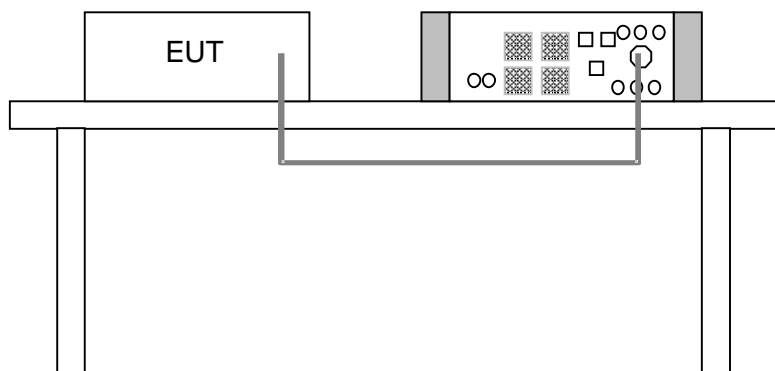

For the actual test configuration, please refer to the related item – Photographs of the Test Configuration.



5.12.6 TEST RESULTS

TEST MODE	Mode 2A & Mode 3A	INPUT POWER	230Vac, 50Hz
ENVIRONMENTAL CONDITIONS	25deg. C, 69% RH	TESTED BY: Ken Chen	

Frequency (Hz)	Field Strength (V_{r.m.s.})	Cable	Observation	Performance Criterion
140 – 360	10	Power Mains	Note	A

NOTE: There was no change compared with the initial operation during the test.

6 PHOTOGRAPHS OF THE TEST CONFIGURATION

CONDUCTED EMISSION TEST - For Mode 1 & 3





A D T

CONDUCTED EMISSION TEST - For Mode 2



TELECOMMUNICATION PORT - RJ45 OF CONDUCTED EMISSION TEST - For Mode 1 & 3

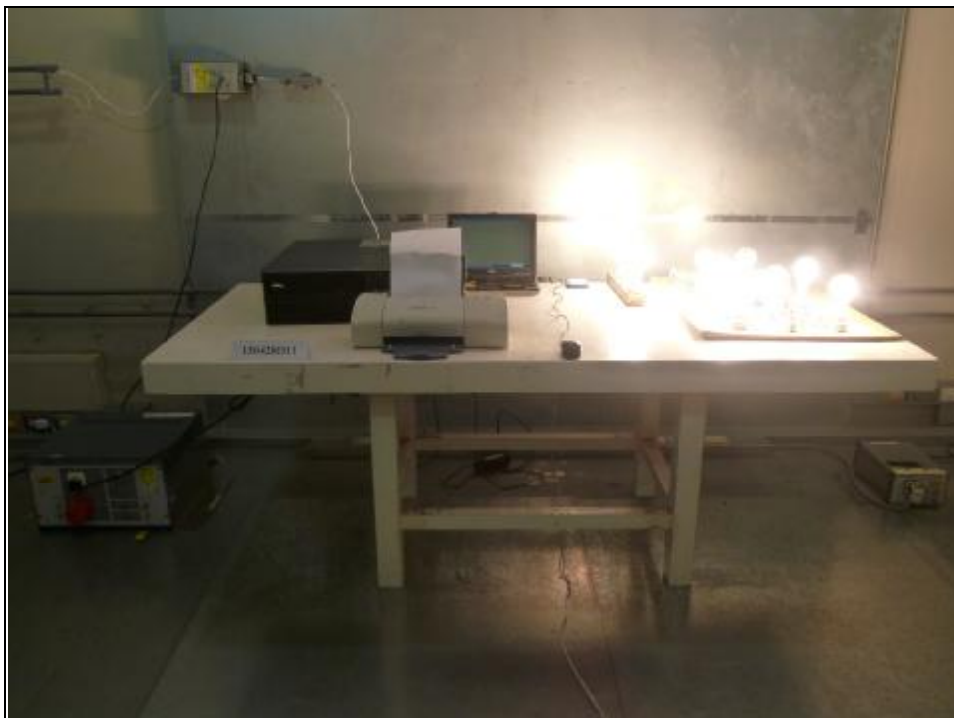



A D T

TELECOMMUNICATION PORT - RJ45 OF CONDUCTED EMISSION TEST - For Mode 2



RADIATED EMISSION TEST - For Mode 1 & 3



RADIATED EMISSION TEST - For Mode 2



HARMONICS EMISSION TEST & VOLTAGE FLUCTUATIONS AND FLICKER TEST

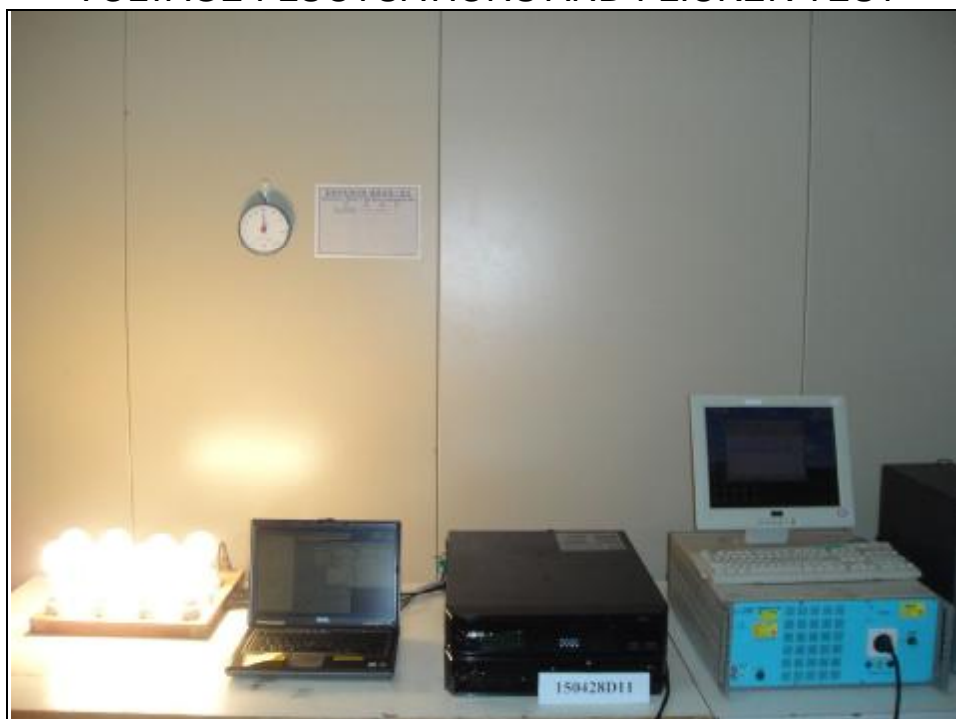

ESD TEST



ESD TEST POINT - for Model SRT3000RMXLW-IEC

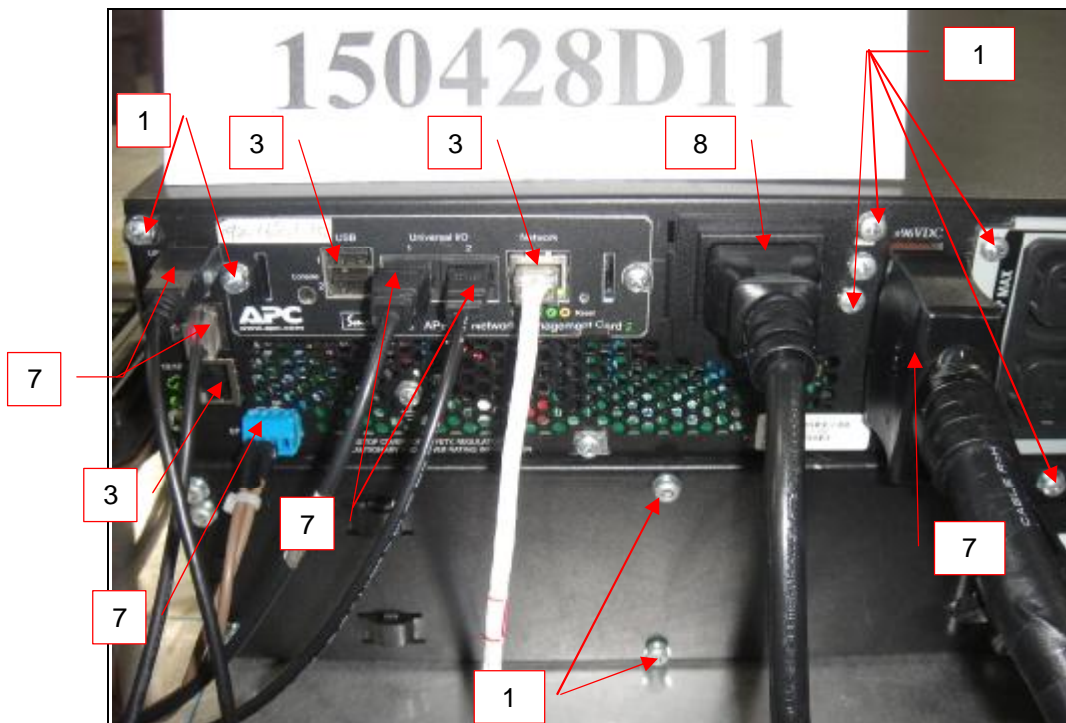

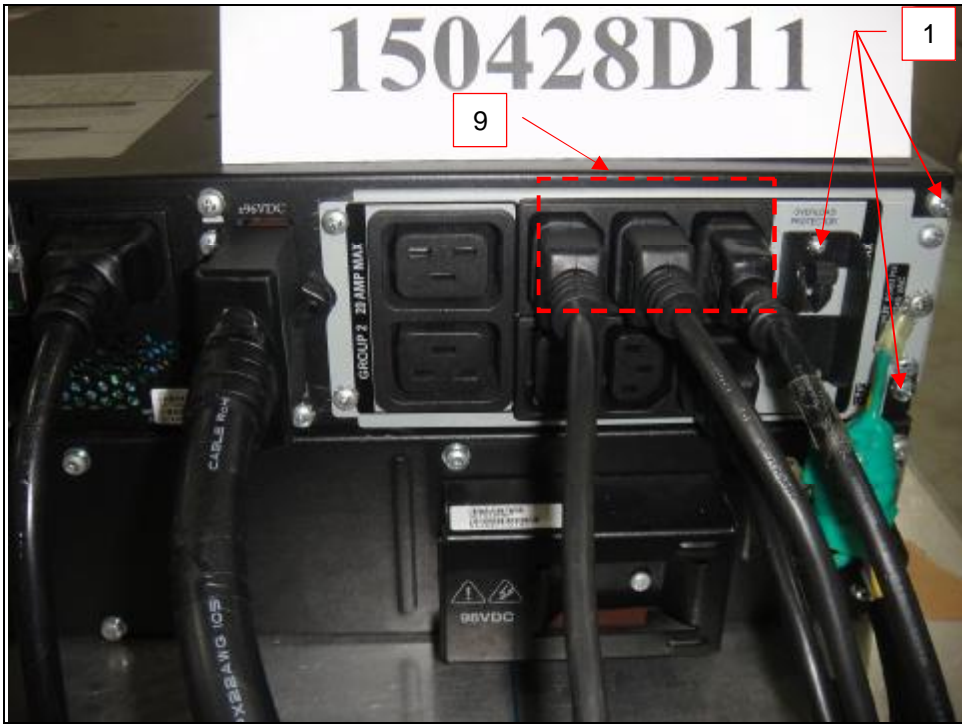

ESD TEST POINT- for Model SRT2200RMXLI

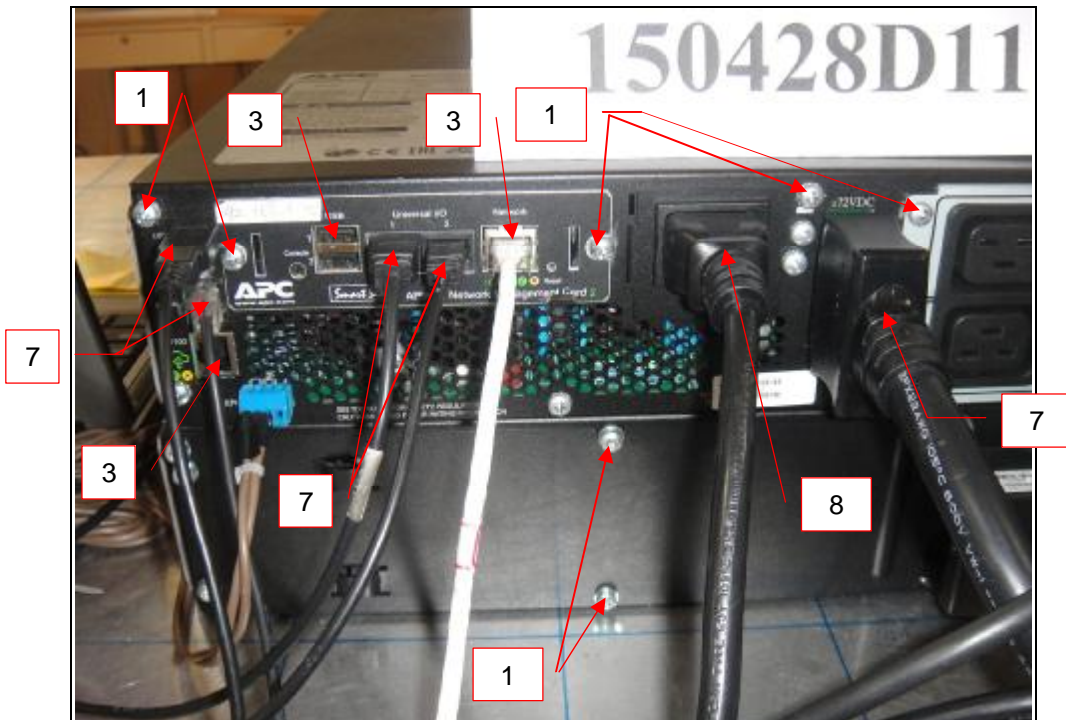
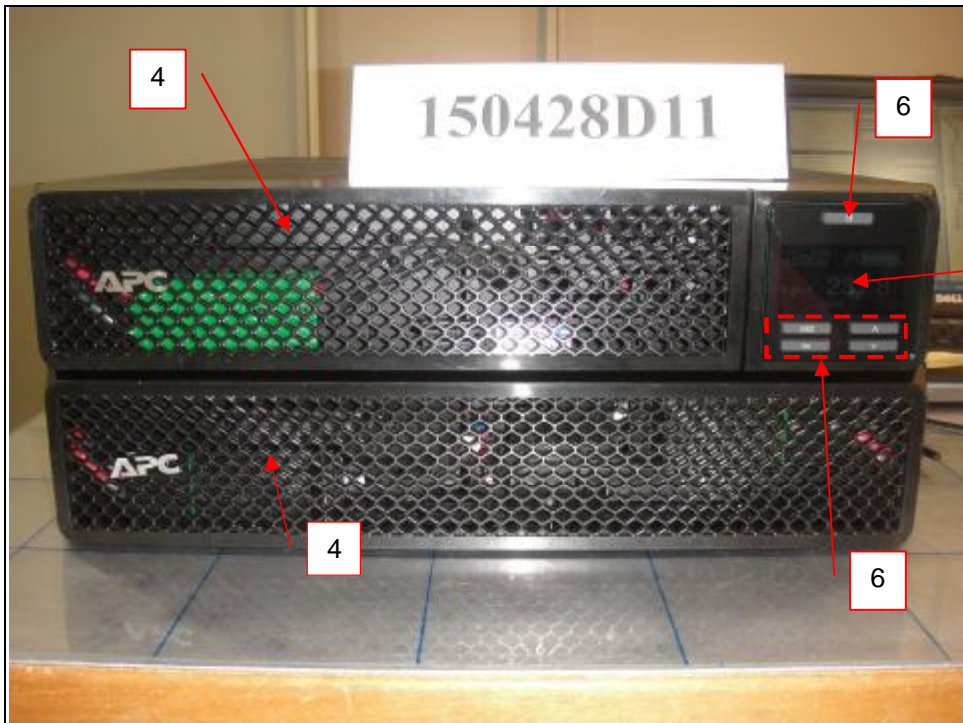



RS TEST - for Model SRT3000RMXLW-IEC

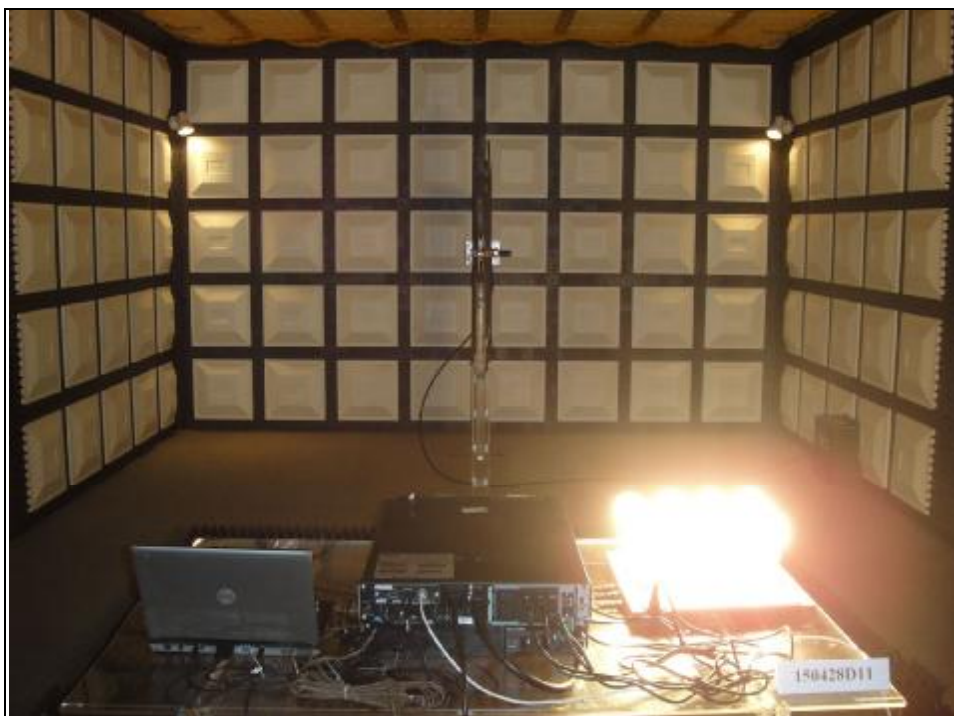

RS TEST - for Model SRT2200RMXLI



EFT TEST <AC in>

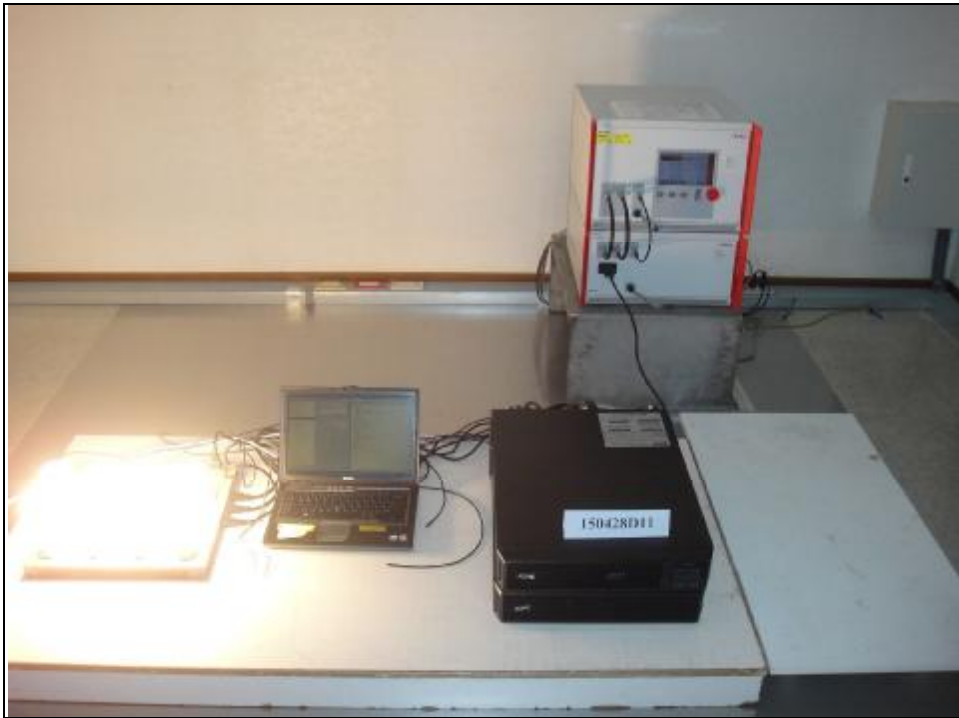

<AC out>



<EPO>



<LAN>



<RS232>



< Universal IO >



< USB >



SURGE TEST <AC in>



<AC out>



<LAN>



CONDUCTED SUSCEPTIBILITY TEST <AC in>

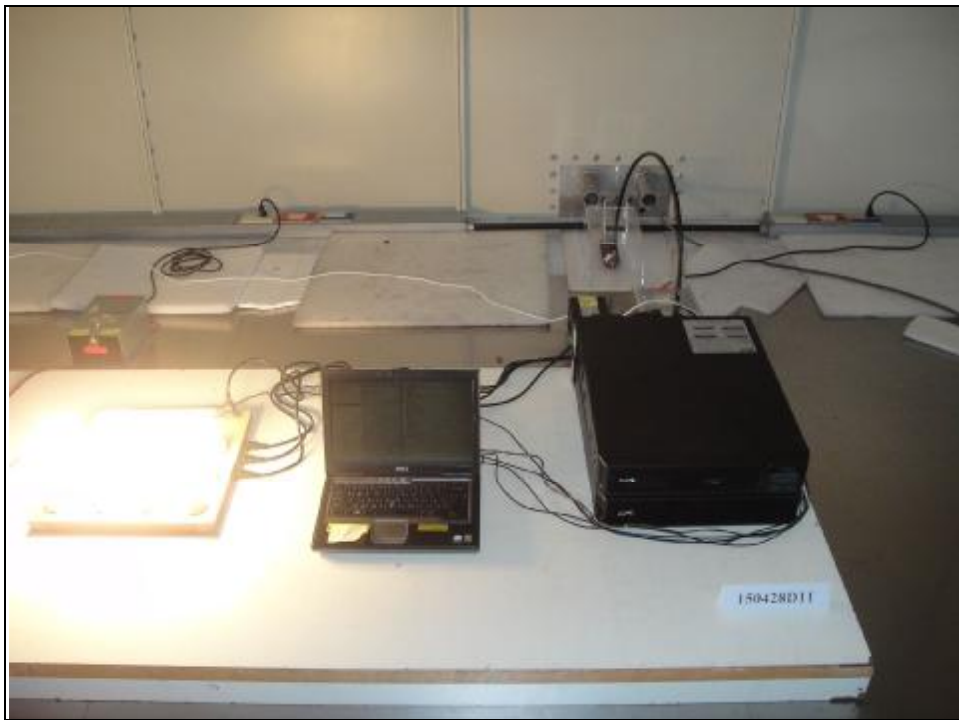

<AC out>

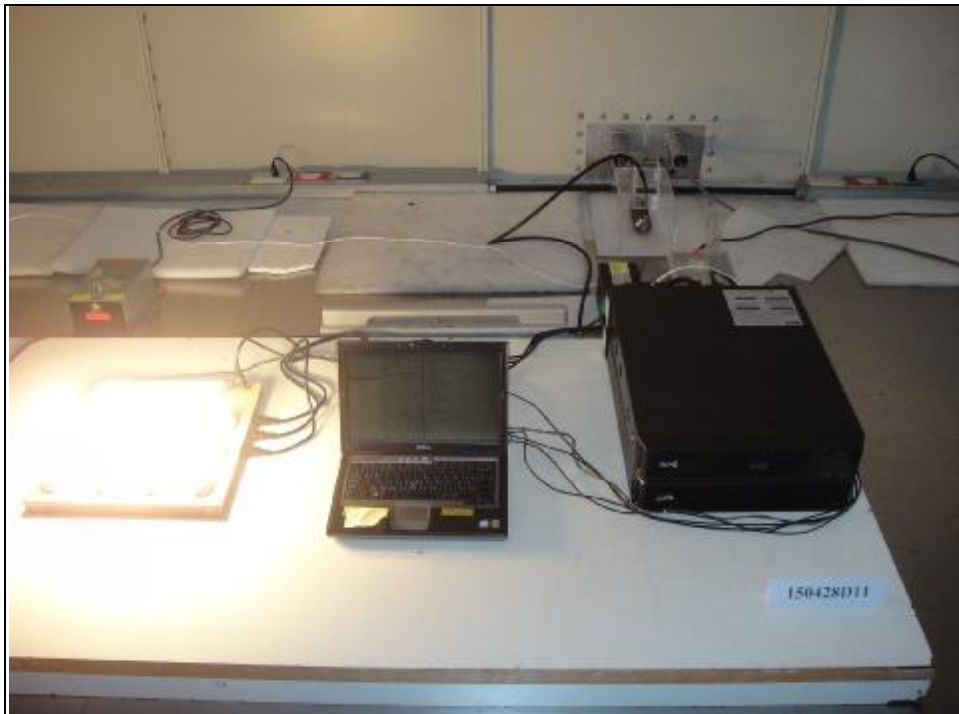

<EPO>

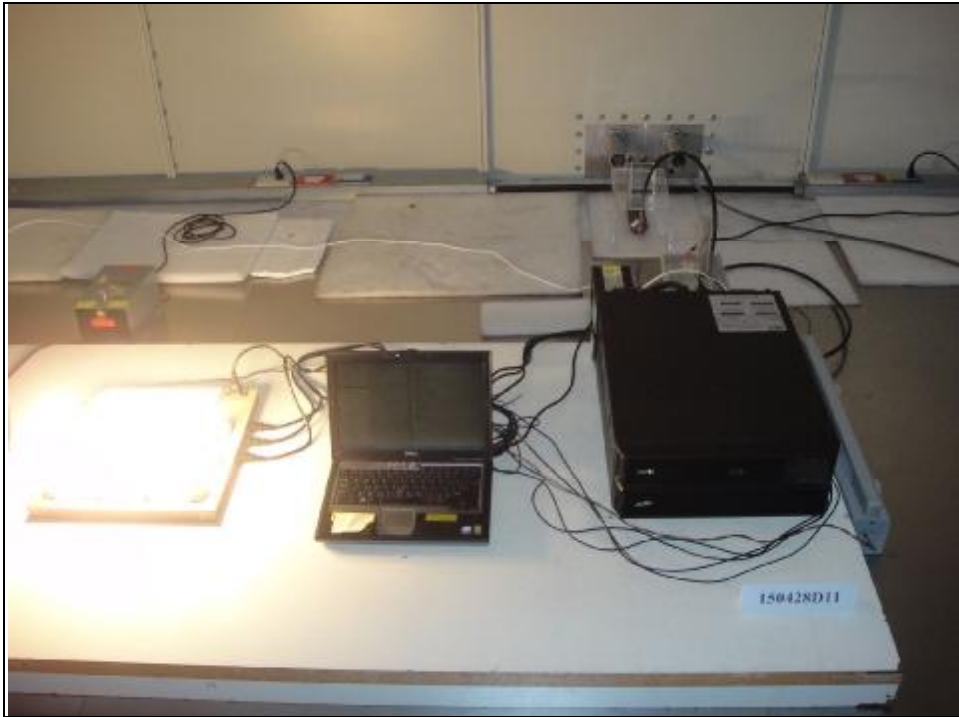

<LAN>

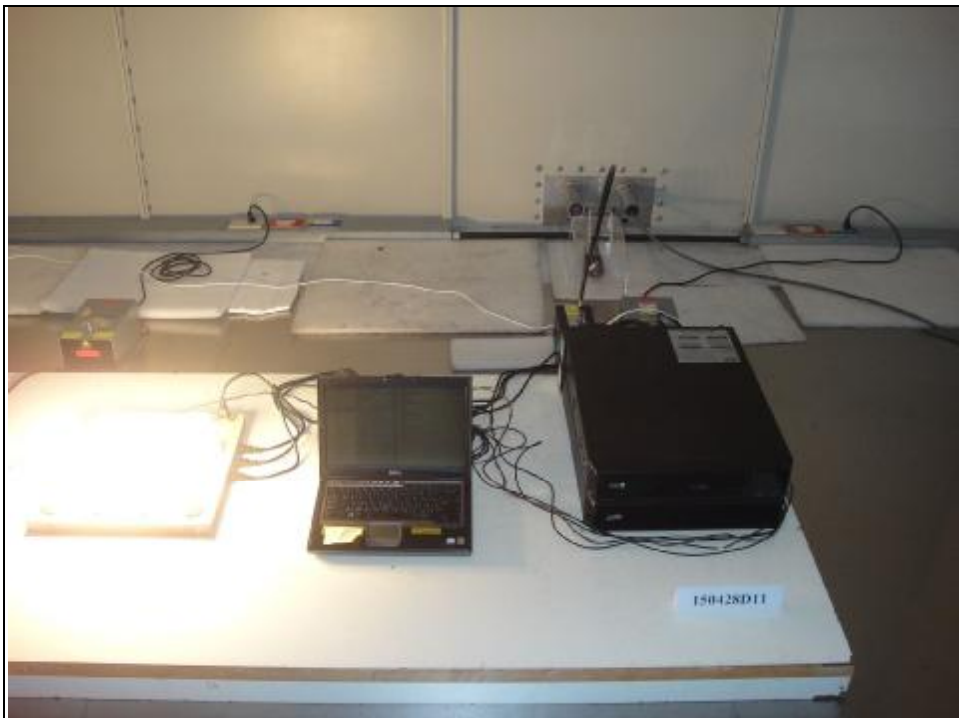

<RS232>

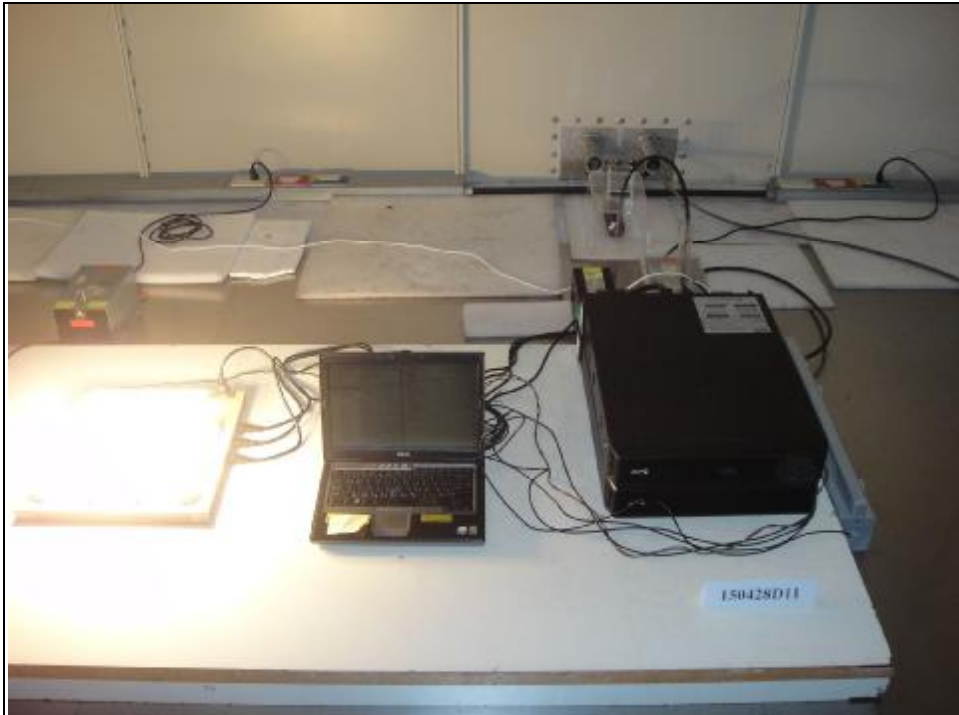

< Universal IO >

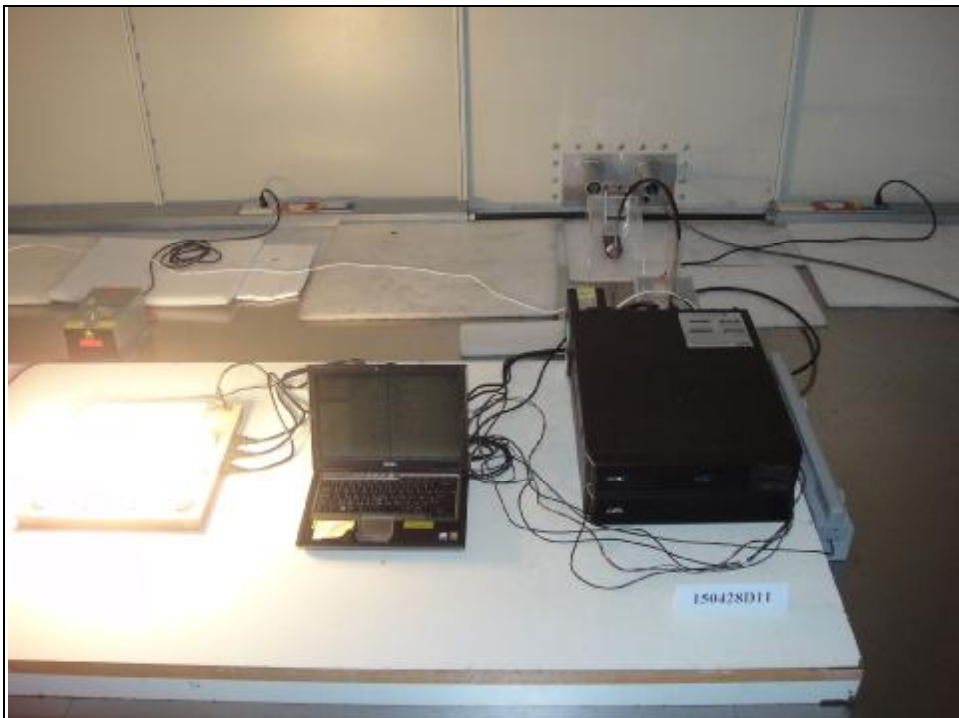

< USB >

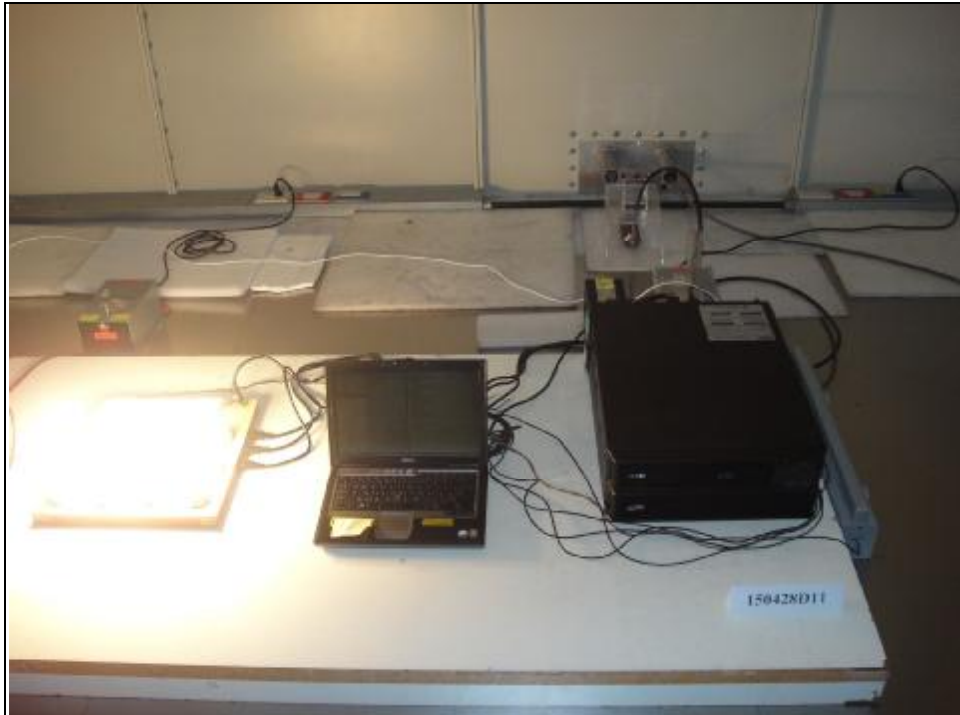

POWER-FREQUENCY MAGNETIC FIELDS TEST



VOLTAGE DIPS AND INTERRUPTIONS TEST





A D T

LOW-FREQUENCY TEST





7 APPENDIX - INFORMATION ON THE TESTING LABORATORIES

We, Bureau Veritas Consumer Products Services (H.K.) Ltd., Taoyuan Branch, were founded in 1988 to provide our best service in EMC, Radio, Telecom and Safety consultation. Our laboratories are accredited and approved according to ISO/IEC 17025.

If you have any comments, please feel free to contact us at the following:

Linko EMC/RF Lab

Tel: 886-2-26052180

Fax: 886-2-26051924

Hsin Chu EMC/RF/Telecom Lab

Tel: 886-3-5935343

Fax: 886-3-5935342

Hwa Ya EMC/RF/Safety Lab

Tel: 886-3-3183232

Fax: 886-3-3270892

Email: service.adt@tw.bureauVeritas.com

Web Site: www.bureauVeritas-adt.com

The address and road map of all our labs can be found in our web site also.



A D T

8 APPENDIX A - ADD RS TEST

Applicant				Application No.	
Device	UPS	Model No.	SRT2200RMXLI	Test Dated :	2015/06/09
Test Specification	<input type="checkbox"/> IEC 61000-4-3 <input type="checkbox"/> EN 61000-4-3				
Equipment	Manufacturer	Model No.	Calibration Date	Next Cal. Date	
UPL AUDIO ANALYZER	Rohde & Schwarz	UPL	2014/11/04	2017/10/31	
Antenna	SUNOL SCIENCES	JB6	N/A	N/A	
signal Generator	Rohde & Schwarz	SMB100A	2014/06/24	2015/06/23	
Amplifier	Ophir	5172F	N/A	N/A	
Amplifier	Ophir	5127F	N/A	N/A	
POWER METER	Boonton	4232A	2014/10/04	2015/10/03	
Climatic Condition	Ambient Temperature: <u>23</u> °C Relative Humidity: <u>44</u> % RH Atmospheric Pressure: <u>990</u> mbar				
Power Supply System	AC Power : <u>230</u> Vac <u>50</u> Hz				
Test Set-up	Table-top Equipment				
Operating Conditions of The Device	Operation ,Mode				

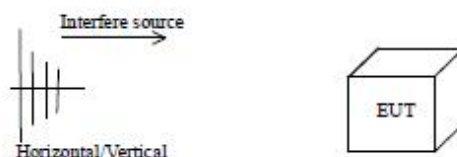

Frequency Range	<u>27</u> MHz ~ <u>80</u> MHz	Field Strength	<u>10</u> V/m	Modulation (AM 1kHz 80%)
Sweep Rate	: $\leq 1.5 \times 10^{-3}$ ecades/s	Step Size	: ≤ 1 % of preceding frequency value	Dwell Time : <u>3</u> s
Frequency Range (MHz)	Polarization of Device	Directing of Device	Test Result	
<u>27</u> MHz ~ <u>80</u> MHz	Vertical	Front	A	

Note : "A" means the EUT function was correct during the test.



A D T

Applicant				Application No.	
Device	UPS	Model No.	SRT3000RMXLT-IEC	Test Dated :	2015/06/09
Test Specification	<input type="checkbox"/> IEC 61000-4-3 <input type="checkbox"/> EN 61000-4-3				
Equipment	Manufacturer	Equipment	Manufacturer	Equipment	
UPL AUDIO ANALYZER	Rohde & Schwarz	UPL	2014/11/04	2017/10/31	
Antenna	SUNOL SCIENCES	JB6	N/A	N/A	
signal Generator	Rohde & Schwarz	SMB100A	2014/06/24	2015/06/23	
Amplifier	Ophir	5172F	N/A	N/A	
Amplifier	Ophir	5127F	N/A	N/A	
POWER METER	Boonton	4232A	2014/10/04	2015/10/03	
Climatic Condition	Ambient Temperature: <u>23</u> °C Relative Humidity: <u>44</u> % RH Atmospheric Pressure: <u>990</u> mbar				
Power Supply System	AC Power : <u>230</u> Vac <u>50</u> Hz				
Test Set-up	Table-top Equipment				
Operating Conditions of The Device	Operation ,Mode				

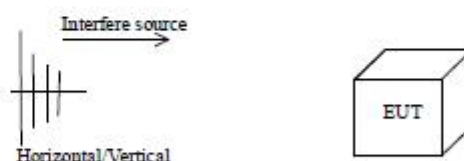

Frequency Range	<u>27</u> MHz ~ <u>80</u> MHz	Field Strength	<u>10</u> V/m	Modulation (AM 1kHz 80%)
Sweep Rate	: $\leq 1.5 \times 10^{-3}$ octaves/s	Step Size	: ≤ 1 % of preceding frequency value	
		Dwell Time	: <u>3</u> s	
Frequency Range (MHz)	Polarization of Device	Directing of Device	Test Result	
<u>27</u> MHz ~ <u>80</u> MHz	Vertical	Front	A	

Note : "A" means the EUT function was correct during the test.

---END---